



MARRI LAXMAN REDDY
INSTITUTE OF TECHNOLOGY AND MANAGEMENT

(AN AUTONOMOUS INSTITUTION)
(Approved by AICTE, New Delhi & Affiliated to JNTUH, Hyderabad)

Accredited by NBA and NAAC with 'A' Grade & Recognized Under Section 2(f) & 12(B) of the UGC act, 1956

LABORATORY MANUAL
ANALOG AND DIGITAL COMMUNICATIONS LAB

II B. TECH -II SEMESTER (ECE)
MLRS-R25 REGULATION



AY-2026-2027

DEPARTMENT OF ELECTRONICS AND COMMUNICATION ENGINEERING

COURSE STRUCTURE, OBJECTIVES & OUTCOMES

COURSE STRUCTURE

Level	Credits	Periods/week	Prerequisites
UG	1	3	-

Evaluation Scheme:

MID (Internal Lab) Semester Test	30 marks
Day to day evaluation	10 marks
End Semester Lab external Examination	60 marks

The end semester examination shall be conducted with an external examiner and internal examiner.

The external examiner shall be appointed by the principal / Chief Controller of examinations.



MARRI LAXMAN REDDY
INSTITUTE OF TECHNOLOGY AND MANAGEMENT

(AN AUTONOMOUS INSTITUTION)

(Approved by AICTE, New Delhi & Affiliated to JNTUH, Hyderabad)

Accredited by NBA and NAAC with 'A' Grade & Recognized Under Section 2(f) & 12(B) of the UGC act, 1956

DEPARTMENT OF ELECTRONICS AND COMMUNICATION
ANALOG AND DIGITAL COMMUNICATIONS LABORATORY

Virtual lab details

Name of the Virtual Lab: NA
Virtual Lab Host Institute: NA
URL/Link to Lab: NA
Academic Year: NA
Semester: NA



MARRI LAXMAN REDDY **INSTITUTE OF TECHNOLOGY AND MANAGEMENT**

(AN AUTONOMOUS INSTITUTION)

(Approved by AICTE, New Delhi & Affiliated to JNTUH, Hyderabad)

Accredited by NBA and NAAC with 'A' Grade & Recognized Under Section 2(f) & 12(B) of the UGC act, 1956

DEPARTMENT OF ELECTRONICS AND COMMUNICATION ENGINEERING ANALOG AND DIGITAL COMMUNICATIONS LAB

LAB PLANNER

S.No	Experiment	CO	Virtual Lab Availability	Date planned	Date conducted
1	Amplitude modulation: Generation and Detection	CO1	NA		
2	Double Side Band Modulation: Generation and Detection	CO1	NA		
3	Single Modulation (Phase Shift Method): Generation and Detection	CO2	NA		
4	Frequency modulation: Generation and Detection	CO2	NA		
5	Study of spectrum analyzer using AM/FM signals.	CO2	NA		
6	Design & Implementation of pre-emphasis & de-emphasis filters	CO3	NA		
7	Time division multiplexing & de-multiplexing of any two band limited signals	CO3	NA		
8	LAB INTERNAL-1				
9	Verification of sampling theorem	CO3	NA		
10	Pulse amplitude modulation: Generation and detection	CO3	NA		
11	Pulse code modulation: Generation and detection	CO4	NA		
12	Differential pulse code modulation: Generation and detection	CO4	NA		
13	Delta modulation: Generation and detection	CO5	NA		
14	Amplitude shift keying: Generation and detection	CO5	NA		
15	Frequency shift keying: Generation and detection	CO5	NA		
16	LAB INTERNAL-2				



MARRI LAXMAN REDDY INSTITUTE OF TECHNOLOGY AND MANAGEMENT

(AN AUTONOMOUS INSTITUTION)

(Approved by AICTE, New Delhi & Affiliated to JNTUH, Hyderabad)

Accredited by NBA and NAAC with 'A' Grade & Recognized Under Section 2(f) & 12(B) of the UGC act, 1956

DEPARTMENT OF ELECTRONICS AND COMMUNICATION ENGINEERING ANALOG AND DIGITAL COMMUNICATIONS LAB

RUBRICS USED TO ASSESS LEARNINGS IN LABORATORIES

1. RUBRICS FOR DAY-TO-DAY EVALUATION

Parameter	Max Marks	Level-1 (Very Poor)	Level-2 (Poor)	Level-3 (Average)	Level-4 (Good)	Level-5 (Excellent)
Observation Book	05	No observations or irrelevant data. (0-1)	Incomplete or incorrect data. (2)	Basic values with some errors. (3)	Mostly correct with good format. (4)	Fully correct, clear, and well-formatted. (5)
Record Writing	05	Not submitted. (0-1)	Submitted but mostly incomplete. (2)	Submitted with some missing/wrong parts. (3)	Submitted with minor issues. (4)	Fully complete, correct algorithm & flowchart. (5)
Result	05	No result or major errors. (0-1)	Result partially obtained. (2)	Acceptable result with limited error. (3)	Near-correct result and reasonable error. (4)	Accurate result. (5)
Viva-Voce	05	Did not answer any questions. (1)	Answered very few questions. (2)	Answered some questions with help. (3)	Answered most questions correctly. (4)	Answered all questions accurately. (5)



MARRI LAXMAN REDDY INSTITUTE OF TECHNOLOGY AND MANAGEMENT

(AN AUTONOMOUS INSTITUTION)

(Approved by AICTE, New Delhi & Affiliated to JNTUH, Hyderabad)

Accredited by NBA and NAAC with 'A' Grade & Recognized Under Section 2(f) & 12(B) of the UGC act, 1956

DEPARTMENT OF ELECTRONICS AND COMMUNICATION ENGINEERING ANALOG AND DIGITAL COMMUNICATIONS LAB

2. RUBRICS FOR INTERNAL EVALUATION

Criterion	Max Marks	Level-1 (<i>Very Poor</i>)	Level-2 (<i>Poor</i>)	Level-3 (<i>Average</i>)	Level-4 (<i>Good</i>)	Level-5 (<i>Excellent</i>)
Design/Tool/Apparatus Selection	2 Marks	Incorrect tool/design and no reasoning. (0)	Tool/design selection attempted with unclear logic. (0.5)	Satisfactory selection with partial justification. (1)	Correct selection and proper analysis with few errors. (1.5)	Smart selection with accurate, relevant analysis. (2)
Execution (Code/Debug/Run) /Analysis/Method Used	4 Marks	Did not attempt or completely failed to execute. (0)	Attempted but unable to proceed or with major errors. (1)	Partial execution with some logic/syntax errors. (2)	Mostly correct execution with minimal help. (3)	Fully correct and independently executed program. (4)
Results & Documentation	2 Marks	Incomplete or poorly presented. (0)	Basic structure but lacks clarity or formatting. (0.5)	Complete but generic or with formatting issues. (1)	Well-structured and mostly clear. (1.5)	Well-organized, professional, and engaging documentation. (2)
Viva-Voce (Understanding of Concepts)	2 Marks	No understanding; could not answer questions. (0)	Answered a few with difficulty. (0.5)	Answered half the questions with basic clarity. (1)	Good understanding with confident answers. (1.5)	Answered all questions with clarity and depth. (2)



MARRI LAXMAN REDDY INSTITUTE OF TECHNOLOGY AND MANAGEMENT

(AN AUTONOMOUS INSTITUTION)

(Approved by AICTE, New Delhi & Affiliated to JNTUH, Hyderabad)

Accredited by NBA and NAAC with 'A' Grade & Recognized Under Section 2(f) & 12(B) of the UGC act, 1956

DEPARTMENT OF ELECTRONICS AND COMMUNICATION ENGINEERING ANALOG AND DIGITAL COMMUNICATIONS LAB

3. RUBRICS FOR SEMESTER END EXAMINATIONS

Criterion	Max Marks	Level-1 (Very Poor) (0–2 marks)	Level-2 (Poor) (3–4 marks)	Level-3 (Average) (5–6 marks)	Level-4 (Good) (7–9 marks)	Level-5 (Excellent) (10–12 marks)
Preparedness for the Experiment	12 marks	No clarity on objective or procedure. Unable to explain basics.	Limited idea of the objective/procedure. Needed prompting.	Has basic understanding; minor gaps in concept or preparation.	Well-prepared, with clear understanding of steps and background.	Fully prepared with strong conceptual clarity and confident explanation.
Performance in the Laboratory	12 marks	Unable to perform experiment. Relied entirely on examiner's help.	Performed with multiple errors and constant support.	Performed with some errors; required occasional help.	Performed mostly independently with minimal support.	Performed independently, efficiently, and with precision.
Calculations & Graphs	12 marks	No or incorrect calculations. Graphs missing or irrelevant.	Multiple calculation errors. Graphs/plots inaccurate or poorly labeled.	Calculations partially correct. Graphs present but with some flaws.	Correct calculations and graphs with minor errors.	Accurate calculations and well-labeled graphs with proper interpretation.
Results & Error Analysis	12 marks	No result or invalid result. No error analysis attempted.	Incorrect result with vague or no error discussion.	Acceptable result. Error analysis attempted but limited.	Correct result with sound error discussion.	Accurate result with detailed and relevant error analysis.
Viva-Voce (Subject Knowledge)	12 marks	Unable to answer any questions. No conceptual understanding.	Answered few questions with poor logic.	Answered half of the questions with average understanding.	Answered most questions with clarity and confidence.	Answered all questions with depth, clarity, and reasoning.



MARRI LAXMAN REDDY **INSTITUTE OF TECHNOLOGY AND MANAGEMENT**

(AN AUTONOMOUS INSTITUTION)

(Approved by AICTE, New Delhi & Affiliated to JNTUH, Hyderabad)

Accredited by NBA and NAAC with 'A' Grade & Recognized Under Section 2(f) & 12(B) of the UGC act, 1956

INDEX

S. No	CONTENTS	Page No
1	CERTIFICATE	i
2	PREFACE	ii
3	ACKNOWLEDGEMENT	iii
4	GENERAL INSTRUCTIONS	iv
5	SAFETY PRECAUTIONS	v
6	INSTITUTE VISION AND MISSION	vi
7	DEPARTMENT VISION MISSION, PROGRAMME EDUCATIONAL OBJECTIVES	vii
8	PROGRAMME OUTCOMES-PROGRAMME SPECIFIC OUTCOMES	vii
9	COURSE STRUCTURE, OBJECTIVES & OUTCOMES	x
10	CO-PO MAPPING	xi
11	EXPERIMENTS	xii
12	Amplitude modulation: Generation and Detection	1-14
13	Double Side Band Modulation: Generation and Detection	15-21
14	Single Modulation (Phase Shift Method): Generation and Detection	22-31
15	Frequency modulation: Generation and Detection	32-42
16	Study of spectrum analyzer using AM/FM signals.	43-52
17	Design & Implementation of pre-emphasis & de-emphasis filters	53-61
18	Time division multiplexing & de-multiplexing of any two band limited signals	62-66
19	Verification of sampling theorem	67-70
20	Pulse amplitude modulation: Generation and detection	71-80
21	Pulse code modulation: Generation and detection	81-86
22	Differential pulse code modulation: Generation and detection	87-91
23	Delta modulation: Generation and detection	92-96
24	Amplitude shift keying: Generation and detection	97-100
25	Frequency shift keying: Generation and detection	101-105
26	Phase shift keying: Generation and detection	106-110

CERTIFICATE

This is to certify that this manual is a Bonafide record of practical work in the **Analog and Digital Communications lab** in **IVth Semester of II -year B. Tech Sem II (ECE) Programme** during the academic year **2026-2027**. This book is prepared by **Mrs. P.Lavanya (Assistant Professor)** Department of Electronics and Communication Engineering.

LAB I/C

Head of the Department

PREFACE

It is one of the core areas of ECE and constitutes the largest applications in use today. Communication has entered into every part of today's world. This laboratory is intended to make students understand the use of different Analog and Digital Communications Engineering Lab is designed to help students understand the basic principles of communication techniques as well as giving them the insight on design, simulation and hardware implementation of circuits. The main aim is to provide hands-on experience to the students so that they are able to put theoretical concepts to practice. The content of this course consists of two parts, 'simulation' and 'hardwired'. Computer simulation is stressed upon as it is a key analysis tool of engineering design. "SCILAB" and MATLAB software is used for simulation of communication experiments Students will carry out design experiments as a part of the experiments list provided in this lab manual. Students will be given a specific design problem, which after completion they will verify using the simulation software or hardwired implementation.

By,

Mrs. P. Lavanya

ACKNOWLEDGEMENT

It was really a good experience, working with **Analog and Digital Communications Laboratory**. First, we would like to thank **Dr. N. Srinivas**, Assoc. Professor, HOD of Department of Electronics and Communication Engineering, Marri Laxman Reddy Institute of technology & Management for his concern and giving the technical support in preparing the document.

We are deeply indebted and gratefully acknowledge the constant support and valuable patronage of **Dr. Ravi Prasad**, Dean, Marri Laxman Reddy Institute of technology & Management for giving us this wonderful opportunity for preparing the Analog and Digital Communications Laboratory manual.

We express our hearty thanks to **Dr.R. Murali Prasad**, Principal, Marri Laxman Reddy Institute of technology & Management, for timely corrections and scholarly guidance.

At last, but not the least I would like to thanks the entire ECE Department faculty those who had inspired and helped us to achieve our goal.

By,

Mrs. P. Lavanya

GENERAL INSTRUCTIONS

1. Students should report to the concerned labs as per the timetable schedule.
2. Students who turn up late to the labs will in no case be permitted to perform the experiment scheduled for the day.
3. After completion of the experiment, certification of the concerned staff in-charge in the observation book is necessary.
4. Students should bring a notebook of about 100 pages and should enter the readings/observations into the notebook while performing the experiment.
5. The record of observations along with the detailed experimental procedure of the experiment.
6. Performed in the immediate last session should be submitted and certified by the staff member in-charge.
- 7.. Not more than one student is permitted to perform the experiment on a setup.
8. When the experiment is completed, students should disconnect the setup made by them, and should return all the components/instruments taken for the purpose.
9. Any damage of the equipment or burnout of components will be viewed seriously by putting penalty.
10. Students should be present in the labs for the total scheduled duration.
11. Students are required to prepare thoroughly to perform the experiment before coming to Laboratory.
12. Procedure sheets/data sheets provided to the student's should be maintained neatly and to be returned after the experiment.

SAFETY PRECAUTIONS

1. No horseplay or running is allowed in the labs.
2. No bare feet or open sandals are permitted.
3. Before energizing any equipment, check whether anyone is in a position to be injured by your actions.
4. Read the appropriate equipment instruction manual sections or consult with your instructor.
5. Before applying power or connecting unfamiliar equipment or instruments into any circuits.
6. Position all equipment on benches in a safe and stable manner.
7. Do not make circuit connections by hand while circuits are energized. This is especially.
8. Dangerous with high voltage and current circuits.

INSTITUTE VISION AND MISSION

Vision of the Institute

To be a globally recognized institution that fosters innovation, excellence, and leadership in education, research, and technology development, empowering students to create sustainable solutions for the advancement of society.

Mission of the Institute

To foster a transformative learning environment that empowers students to excel in engineering, innovation, and leadership.

To produce skilled, ethical, and socially responsible engineers who contribute to sustainable technological advancements and address global challenges.

To shape future leaders through cutting-edge research, industry collaboration, and community engagement.

Quality Policy

The management is committed in assuring quality service to all its stakeholders, students, parents, alumni, employees, employers, and the community.

Our commitment and dedication are built into our policy of continual quality improvement by establishing and implementing mechanisms and modalities ensuring accountability at all levels, transparency in procedures, and access to information and actions.

DEPARTMENT VISION, MISSION, PROGRAMME EDUCATIONAL OBJECTIVES AND SPECIFIC OUTCOMES

Vision and Mission

Vision of the Department

To provide quality technical education in Electronics and Communication Engineering through research, innovation, striving for global recognition in specified domain, leadership, and sustainable societal solutions.

Mission of the Department

- **DM1:** To create a transformative learning environment that empowers students in electronics and communication engineering, fostering excellence in technical skills and leadership.
- **DM2:** To drive innovation through research, deliver a transformative education grounded in ethical principles, and nurture the development of professionals
- **DM3:** To cultivate strong industry partnerships, and engaging actively with the community for societal and technological progress.

PROGRAMME EDUCATIONAL OBJECTIVES

PEO 1: Have successful careers in Industry

PEO2: Show Excellence in Higher Studies/ Research

PEO3: Show Good competency towards entrepreneurship.

Program Outcomes (PO):

- PO 1:** Engineering knowledge: Apply the knowledge of mathematics, science, engineering fundamentals, and engg. specialization to the solution of complex engineering problems.
- PO 2:** Problem analysis: Identify, formulate, research literature, and analyze engineering problems to arrive at substantiated conclusions using first principles of mathematics, natural, and engineering sciences.
- PO 3:** Design/development of solutions: Design solutions for complex engineering problems and design system components, processes to meet the specifications with consideration for the public health and safety, and the cultural, societal, and environmental considerations.
- PO 4:** Conduct investigations of complex problems: Use research-based knowledge including design of experiments, analysis and interpretation of data, and synthesis of the information to provide valid conclusions.
- PO 5:** Modern tool usage: Create, select, and apply appropriate techniques, resources, and modern engineering and IT tools including prediction and modeling to complex engineering activities with an understanding of the limitations.
- PO 6:** The engineer and society: Apply reasoning informed by the contextual knowledge to assess societal, health, safety, legal, and cultural issues and the consequent responsibilities relevant to the professional engineering practice.
- PO 7:** Environment and sustainability: Understand the impact of the professional engineering solutions in societal and environmental contexts, and demonstrate the knowledge of, and need for sustainable development.
- PO 8:** Ethics: Apply ethical principles and commit to professional ethics and responsibilities and norms of the engineering practice.
- PO 9:** Individual and team work: Function effectively as an individual, and as a member or leader in teams, and in multidisciplinary settings.

PO 10: Communication: Communicate effectively with the engineering community and with society at large. Be able to comprehend and write effective reports documentation. Make effective presentations, and give and receive clear instructions.

PO 11: Project management and finance: Demonstrate knowledge and understanding of engineering and management principles and apply these to one's own work, as a member and leader in a team. Manage projects in multidisciplinary environments.

PO 12: Life-long learning: Recognize the need for, and have the preparation and ability to engage in independent and life-long learning in the broadest context of technological change.

PROGRAM SPECIFIC OUTCOMES

PSO 1: Analyze and design analog & digital circuits or systems for a given specification and function.

PSO 2: Implement functional blocks of hardware-software co-designs for signal processing and communication applications.

PSO 3: Gain the hands-on competency skills in Computing Tools for electronics and communication systems for the entry level position to meet the requirements of the Employer.

COURSE STRUCTURE

Level	Credits	Periods/Week	Prerequisites
UG	1	2	Entire subject of Analog and Digital Communications.

Evaluation Scheme:

MID (Internal Lab) Semester Test	20 marks
Day to day evaluation	20 marks
End Semester Lab external Examination	60marks

The end semester examination shall be conducted with an external examiner and internal examiner.

The external examiner shall be appointed by the principal / Chief Controller of examinations

Course Objectives:

The students will try to learn

- Various analog & digital modulation techniques in communications
- Various spectrums of analog modulation systems using spectrum analyzer
- The importance of automatic gain control and Phase locked loop
- Receiver characteristics in analog & digital communications
- The performance of typical telecommunication system in presence of noise

Course Outcomes:

After successful completion of the course, students shall be able to

- Categorize different modulation & demodulation techniques used in communication system and implement the same using Hardware
- Design pre-emphasis and de-emphasis circuits used in frequency modulation
- Understand the concept of PLL, Digital phase detector and synchronous detector and implement the same using hardware
- Distinguish between NBFM and WBFM signals using Hardware
- Apply ASK, FSK, PSK, PCM, DPCM modulation scheme on a digital signal

LIST OF EXPERIMENTS

1. Amplitude modulation: Generation and detection.
2. Double sideband modulation: Generation and detection.
3. Single modulation (phase shift method): Generation and detection.
4. Frequency modulation: Generation and detection.
5. Study of spectrum analyzer using AM/FM signals.
6. Design & Implementation of pre-emphasis & de-emphasis filters.
7. Time division multiplexing & de-multiplexing of any two band limited signals.
8. Verification of sampling theorem.
9. Pulse amplitude modulation: Generation and detection.
10. Pulse code modulation: Generation and detection.
11. Differential pulse code modulation: Generation and detection.
12. Delta modulation: Generation and detection.
13. Amplitude shift keying: Generation and detection.
14. Frequency shift keying: Generation and detection.
15. Phase shift keying: Generation and detection.

NOTE: Minimum of 12 experiments to be conducted.

AMPLITUDE MODULATION: GENERATION AND DETECTION

EXPT. NO: 1

DATE:

1. AIM:

To generate Amplitude modulated Signal and perform demodulation for different modulation indices. Plot the corresponding waveforms and their spectrum. Compare the modulation index theoretically and practically. Plot the effect of modulating Signal frequency and Amplitude on the modulation index

2. COMPONENTS & TOOLS REQUIRED:

1. Audio signal generator.
2. Carrier signal generator.
3. Amplitude Modulator Trainer Kit.
4. Digital Storage Oscilloscope (30 MHz).
5. CRO Probes.
6. Connecting wires.

3. THEORY:

Modulation is defined as process in which changing the characteristics usually amplitude, frequency and phase of high frequency wave (Carrier wave) by using instantaneous values of the low frequency signal (modulating signal).

Need for modulation:

1. Antenna height and operating frequencies are related each other. So antenna heights are comparable to the quarter wavelengths. For usual audio frequencies antenna heights are unthinkable and impracticable.
2. Audio frequencies are directly transmitted when there is a possibility of mixing with the other frequencies in near by station.
3. If high frequency signals are directly transmitted there is no varying parameter compared to the audio frequency Amplitude modulation is defined as the process in which changing the amplitude of the Carrier wave by using the instantaneous voltages of the modulating signal. In this carrier signal frequency remains constant.

BLOCK DIAGRAM:

MODULATOR:

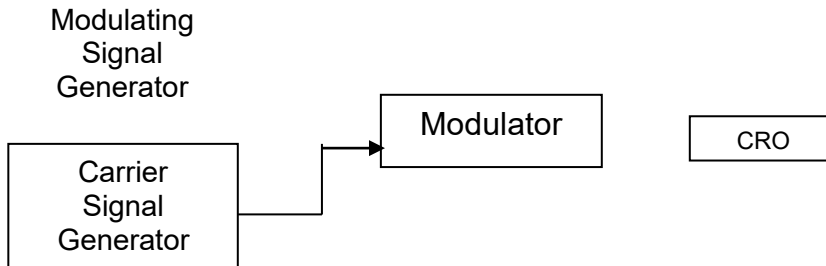

DEMODULATOR:

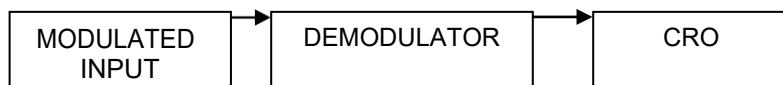

4. MODEL WAVEFORMS:

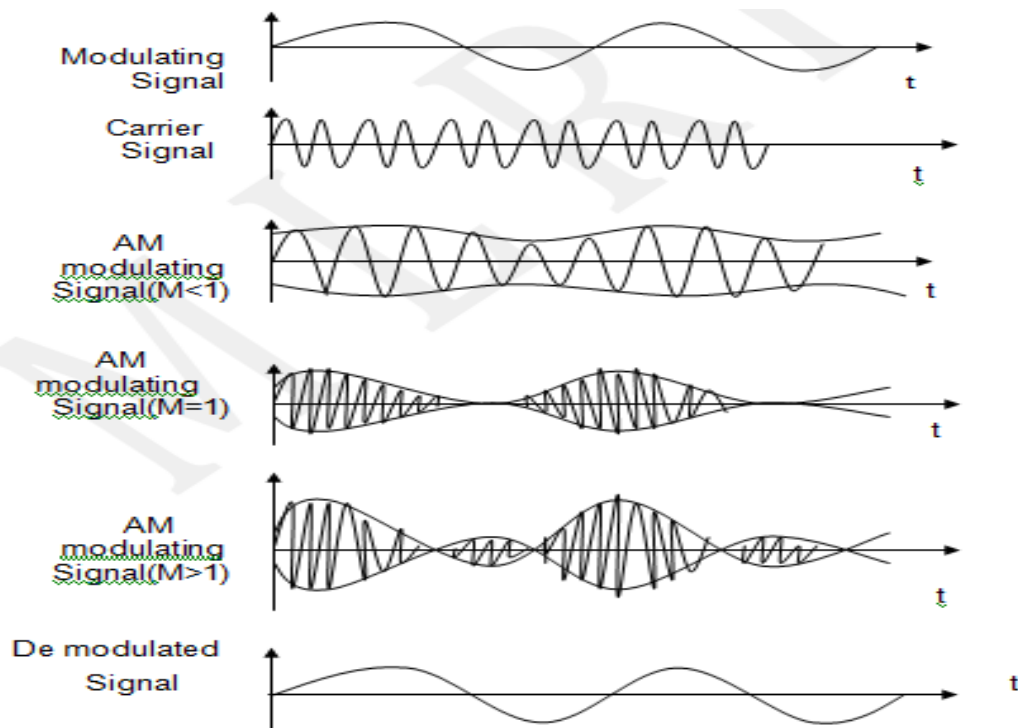

5. EXPERIMENTAL PROCEDURE:

1. Switch on the power supply through mains card.
2. Observe the modulating signal on CRO and set the modulating voltage to 2 V and frequency to 1.56 KHz.
3. Observe the carrier signal on CRO and set the carrier voltage to 2.6 V and frequency to 166.66 KHz.
4. Connect the carrier and modulating signal's to modulator and also connects the output of modulator to CRO and note down the waveforms.
 - a. Find out the maximum and minimum voltages from CRO and from these values Calculate modulation index by using the above formula.
5. Repeating the above procedure for different modulation index and draw the waveforms.
6. Connect the amplitude modulated signal to the demodulator
7. Connect the CRO across the out put terminals of the demodulator
8. Observe the waveforms the modulating signal for different modulation indices.

6. PRECAUTIONS:

1. Check for loose contacts of wires and components.
2. Keep all the control knobs in the minimum position.
3. Before switch ON the power supply get the circuit connections verified by the teacher.
4. Adjust the control knobs smoothly.
5. After taking the readings bring back all the control knobs to minimum position.
6. Switch off the power supply before leaving the experimental table.

8. OBSERVATIONS:

1. Amplitude of modulating signal_____
2. Frequency of modulating signal_____
3. Amplitude of carrier signal_____
4. Frequency of carrier signal_____
5. Amplitude of demodulating signal_____
6. Frequency of demodulating signal_____

USING DECRETE COMPONENTS

AIM:

To Generate Amplitude Modulated Wave using Components

APPARATUS REQUIRED:

S.NO	DESCRIPTION	QUANTITY
1	Transistor BC107	1 No(s)
2	Resistors (47k, 22k, 1.8k, 1.2k, 10k, 100k)	6 No(s)
3	Capacitors (0.01 μ f, 0.1 μ f, 22 μ f)	3 No(s)
4	Function generator (0-1MHz)	1 No(s)
5	CRO	1 No(s)
6	Regulated power supply (0-30V)	1 No(s)
7	Breadboard and connecting wires	--

THEORY:

MODULATION: Modulation is defined as the process by which some characteristics of a carrier signal is varied in accordance with a modulating signal. The base band signal is referred to as the modulating signal and the output of the modulation process is called as the modulation signal. Amplitude modulation is defined as the process in which is the amplitude of the carrier wave is varied about a means value linearly with the base band signal. The envelope of the modulating wave has the same shape as the base band signal provided the following two requirements are satisfied.

1. The carrier frequency f_c must be much greater than the highest frequency components f_m of the message signal $m(t)$ i.e. $f_c \gg f_m$.
2. The modulation index must be less than unity. if the modulation index is greater than unity. The carrier wave becomes over modulated.

DEMODULATION: The process of detection provides a means of recovering the modulating Signal from modulating signal. Demodulation is the reverse process of modulation. The detector circuit is employed to separate the carrier wave and eliminate the side bands.

Since the envelope of an AM wave has the same shape as the message, independent of the carrier frequency and phase, demodulation can be accomplished by extracting envelope. An increased time constant RC results in a marginal output follows the modulation envelope. A further increase in time constant the discharge curve becomes horizontal if the rate of modulation envelope during negative half cycle of the modulation voltage is faster than the rate of voltage RC combination. The output fails to follow the modulation resulting distorted output is called as diagonal clipping this will occur even high modulation index. The depth of modulation at the detector output greater than unity and circuit impedance is less than circuit load ($R_l > Z_m$) results in clipping of negative peaks of modulating signal. It is called “negative clipping”.

CIRCUIT DIAGRAMS:

Modulator:

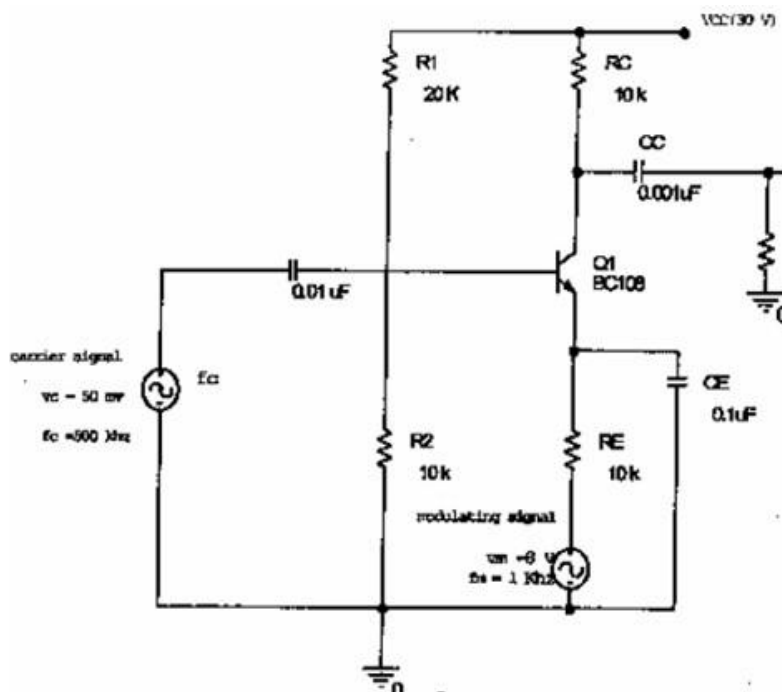

Demodulator:

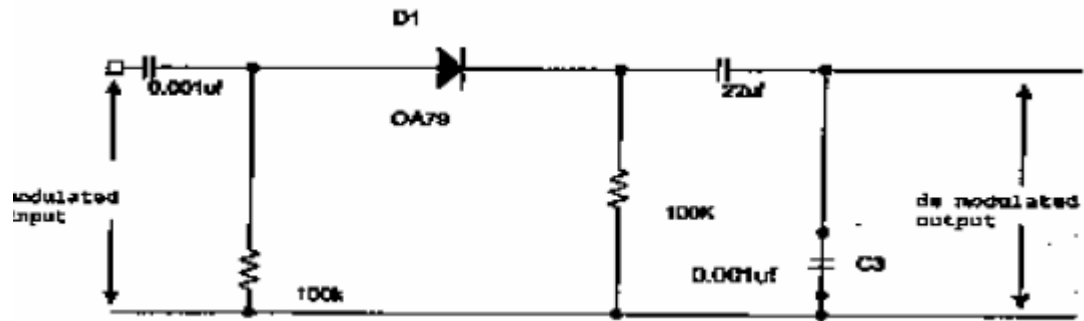

PROCEDURE:

1. Connections are given as per the circuit.
2. Modulating signal and the carrier signal are applied as the input and the corresponding time period and amplitude are noted.
3. Modulated Output is taken from the collector of the Transistor.

EXPECTED WAVEFORMS:

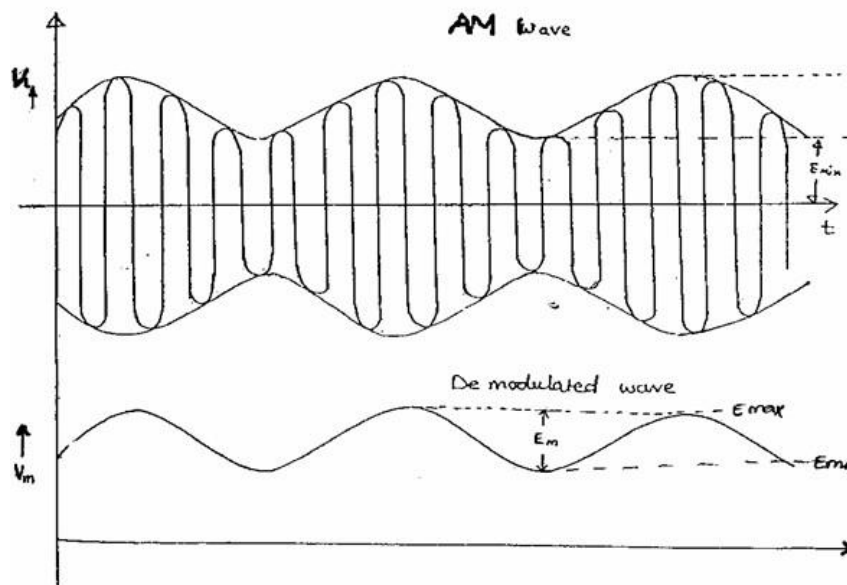

Results:



Thus, Amplitude modulated wave is obtained using discrete components.



Thus, amplitude demodulation wave is generated using discrete components.

SOFTWARE PROGRAM

AIM:

To generate Amplitude Modulation using SCILAB/MATLAB Software for different modulation indices.

APPARATUS REQUIRED:

1. Computer
2. SCILAB/MATLAB SOFTWARE

PROGRAM:

```
fs=8000;
fm=20;
fc=500;
Am=1;
Ac=1;
t=[0:.1*fs]/fs;
m=Am*cos(2*pi*fm*t);
c=Ac*cos(2*pi*fc*t);
ka=0.5;
u=ka*Am;
s1=Ac*(1+u*cos(2*pi*fm*t)).*cos(2*pi*fc*t);
subplot(4,3,1:3);
plot(t,m);
title('Modulating or Message signal(fm=20Hz)');
subplot(4,3,4:6);
plot(t,c);
title('Carrier signal(fc=500Hz)');
subplot(4,3,7);
plot(t,s1);
title('Under Modulated signal(ka.Am=0.5)');
Am=2;
ka=0.5;
u=ka*Am;
s2=Ac*(1+u*cos(2*pi*fm*t)).*cos(2*pi*fc*t);
subplot(4,3,8);
plot(t,s2);
title('Exact Modulated signal(ka.Am=1)');
Am=5;
ka=0.5;
u=ka*Am;
s3=Ac*(1+u*cos(2*pi*fm*t)).*cos(2*pi*fc*t);
subplot(4,3,9);
plot(t,s3);
title('Over Modulated signal(ka.Am=2.5)');
r1= s1.*c;
```

```

[b a] = butter(1,0.01);
mr1= filter(b,a,r1);
subplot(4,3,10);
plot(t,mr1);
r2= s2.*c;
[b a] = butter(1,0.01);
mr2= filter(b,a,r2);
subplot(4,3,11);
plot(t,mr2);
r3= s3.*c;
[b a] = butter(1,0.01);
mr3= filter(b,a,r3);
subplot(4,3,12);
plot(t,mr3);

```

Simulated Wave forms for AM

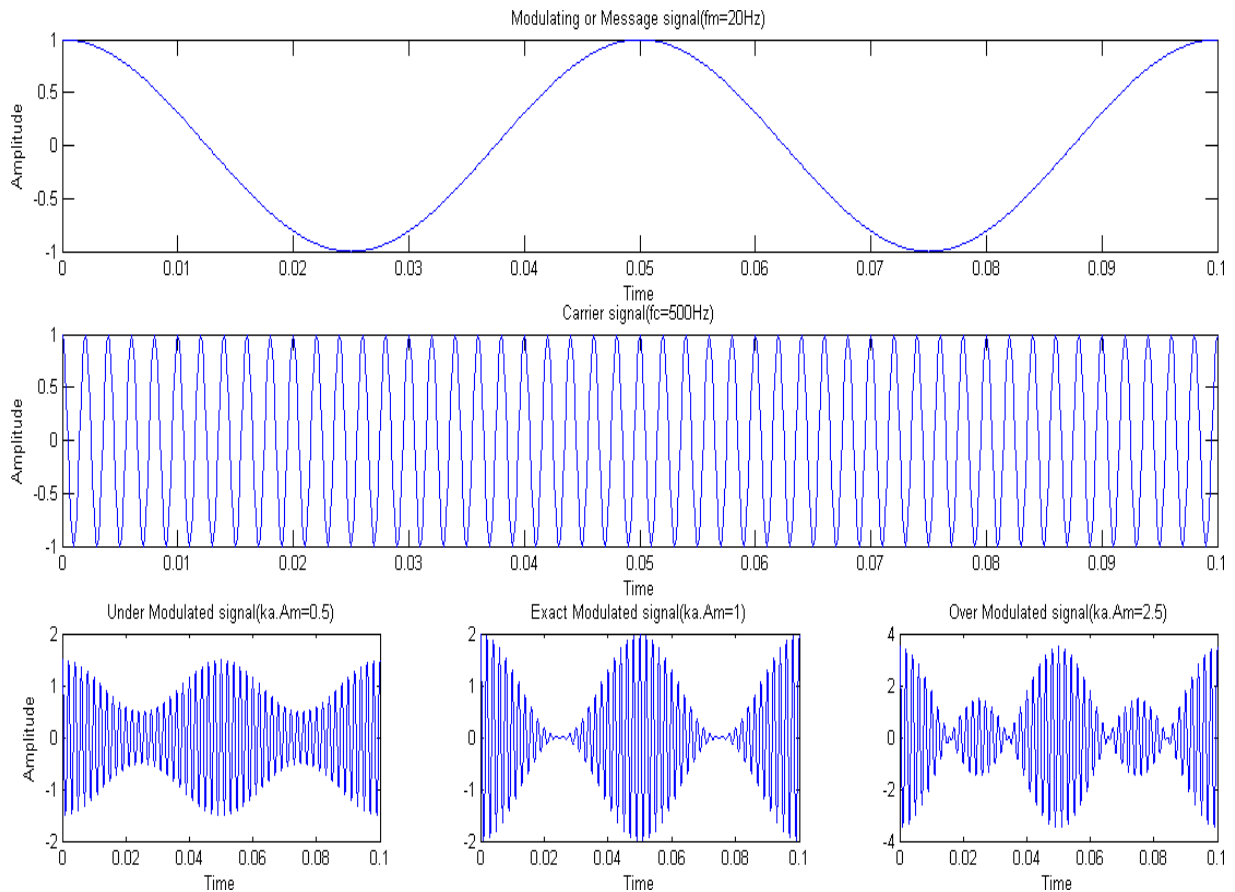

INFERENCE:

Amplitude modulated wave is observed for different modulation indices

EXERCISE:

- 1) Generate an AM wave with message signal $2\cos(\pi t)$ and carrier $-4\sin(1000\pi t)$ with amplitude sensitivity $K_a=0.3$.

- 2) Generate an AM wave with message signal $2\cos(\pi t)$ and carrier $-4\sin(1000\pi t + 10)$ with amplitude sensitivity $K_a = 0.5$
- 3) Generate an AM wave with message signal $2\cos(\pi t + 5)$ and carrier $-4\sin(1000\pi t)$ with amplitude sensitivity $K_a = 0.75$
- 4) Generate an AM wave with message signal $2\cos(\pi t + 5)$ and carrier $-4\sin(1000\pi t + 10)$ with amplitude sensitivity $K_a = 0.5$
- 5) Generate an AM wave with message signal $5\sin(10\pi t + 10)$ and carrier $10\sin(10000\pi t)$ with amplitude sensitivity $K_a = 0.25$
- 6) Generate an AM wave using in-built functions in MATLAB for under modulation.
- 7) Generate an AM wave using in-built functions in MATLAB for perfect modulation.
- 8) Generate an AM wave using in-built functions in MATLAB for over modulation.
- 9) Generate an AM wave with message signal $2\cos(\pi t + 5)$ and carrier $4\sin(1000\pi t + 10)$ with amplitude sensitivity $K_a = 0.56$
- 10) Generate an AM wave with message signal $5\sin(10\pi t + 10)$ and carrier $10\sin(10000\pi t)$ with amplitude sensitivity $K_a = 0.45$
- 11) Generate an AM wave with message signal $4\cos(2\pi t)$ and carrier $4\sin(1000\pi t)$ with amplitude sensitivity $K_a = 0.3$.
- 12) Generate an AM wave with message signal $2\cos(5\pi t)$ and carrier $-4\sin(2000\pi t + 10)$ with amplitude sensitivity $K_a = 0.5$
- 13) Generate an AM wave with message signal $4\cos(4\pi t + 5)$ and carrier $4\sin(5000\pi t)$ with amplitude sensitivity $K_a = 0.75$
- 14) Generate an AM wave with message signal $2\cos(6\pi t + 5)$ and carrier $4\sin(1000\pi t + 10)$ with amplitude sensitivity $K_a = 1$
- 15) Generate an AM wave with message signal $5\sin(20\pi t + 10)$ and carrier $10\sin(20000\pi t)$ with amplitude sensitivity $K_a = 0.2$
- 16) Generate an AM wave using in-built functions in MATLAB for under modulation.
- 17) Generate an AM wave with message signal $20\cos(10\pi t + 5)$ and carrier $-4\sin(2000\pi t + 10)$ with amplitude sensitivity $K_a = 0.7$
- 18) Generate an AM wave with message signal $50\sin(100\pi t + 10)$ and carrier $100\sin(20000\pi t)$ with amplitude sensitivity $K_a = 0.6$
- 19) Generate an AM wave with message signal $20\cos(20\pi t + 10)$ and carrier $-4\sin(2000\pi t + 10)$ with amplitude sensitivity $K_a = 0.7$
- 20) Generate an AM wave with message signal $50\sin(100\pi t + 20)$ and carrier $100\sin(20000\pi t)$ with amplitude sensitivity $K_a = 0.6$
- 21) Generate an AM wave using in-built functions in MATLAB for over modulation.
- 22) Generate an AM wave with message signal $50\cos(10\pi t + 20)$ and carrier $-12\sin(500\pi t + 10)$ with amplitude sensitivity $K_a = 0.5$
- 23) Generate an AM wave with message signal $100\sin(100\pi t + 10)$ and carrier $50\sin(30000\pi t)$ with amplitude sensitivity $K_a = 0.8$
- 24) Generate an AM wave with message signal $10\cos(20\pi t + 10)$ and carrier $-40\sin(2000\pi t + 10)$ with amplitude sensitivity $K_a = 0.9$
- 25) Generate an AM wave with message signal $5\sin(100\pi t + 20)$ and carrier $10\sin(10000\pi t)$ with amplitude sensitivity $K_a = 0.3$

9. CONCLUSION:

For various modulation indices the amplitude modulation and de-modulation is verified.

10. VIVA -VOCE QUESTIONS:

- 1) What is modulation?
- 2) Define modulation index?
- 3) What is the condition for over modulation?
- 4) In modulation what parameters of the high frequency signal are varied?
- 5) What are the basic types of modulation techniques?
- 6) Define Amplitude Modulation index?
- 7) Define percentage Modulation?
- 8) Define DSB-FC.
- 9) What is the need for modulation index?
- 10) What is the need for modulation?
- 11) what are the units of amplitude sensitivity
- 12) What is the percentage of carrier in AM?
- 13) What is communication?
- 14) What is communication system?
- 15) What is the purpose of communication?
- 16) Define SSB.
- 17) Why communication is concerned with electronic equipment?
- 18) What are the basic components of communication system?
- 19) Draw the block diagram of electronic communication system?
- 20) What do you mean by noise?
- 21) Define DSB- SC.
- 22) What are the different types of CS according to their communication media?
- 23) What are the typical channels used in wire/line communication?
- 24) What are the typical channels used in wireless communication?
- 25) What is the functionality of a transmitter and receiver?
- 26) What are baseband signals and what are its frequency ranges?
- 27) What is baseband transmission?
- 28) Define VSB.

- 29) What do you mean by bandwidth and how it is measured?
- 30) What is the need for modulation (or) limitation of baseband signals?
- 31) How modulation is achieved?
- 32) What are the different types of modulations?
- 33) What is multiplexing?
- 34) What are the advantages over modulation techniques?
- 35) Define AM?
- 36) Appraise bandwidth of a signal.
- 37) In modulation what parameters of the high frequency signal are varied?
- 38) What are the basic types of modulation techniques?
- 39) Define Amplitude Modulation index?
- 40) Define percentage Modulation?
- 41) What are the reasons for doing modulation?
- 42) what are the units of amplitude sensitivity
- 43) What is the percentage of carrier in AM?
- 44) Define spectrum of signal.
- 45) Plot the AM spectrum.
- 46) Plot the DSB-FC spectrum.
- 47) Plot the DSB-FC spectrum.
- 48) Plot the DSB-SC spectrum.
- 49) Plot the SSB-FC spectrum.
- 50) Plot the SSB-SC spectrum.
- 51) Plot the VSB spectrum.

11. REAL-TIME APPLICATIONS

1. AM was the earliest modulation method used to transmit voice by radio. It remains in use today in many forms of communication; for example it is used in portable two way radios, VHF aircraft radio, Citizen's Band Radio and in computer modems. "AM" is often used to refer to medium wave AM radio broadcasting.
2. In olden days all radio stations followed only amplitude modulation to propagate the signals. Presently still some of the radio stations follow the same and mostly have switched over to frequency modulation. Especially in TV transmission the picture signal is propagated only by amplitude modulation. The amplitude of a carrier wave is modulated by a data signal and transmitted, for example by radio wave. At the receiving

end it is possible to demodulate the signal if the original carrier wave is known and retrieve the data signal.

3. Amplitude modulation is one way to carry information on a carrier, such as a radio signal. Another way is FM (Frequency Modulation). While FM offers greater clarity for audio, and the higher frequencies that FM use offer a wider bandwidth, allowing for more information to be transmitted, one application where FM and digital are not suitable are Aviation communication, which to this day still use AM analogue. This is because weaker signals can be heard over stronger, closer ones with AM, allowing for emergency transmissions to have more chance of being heard over other traffic. Also, AM uses a narrower bandwidth than FM, allowing more users in a smaller space. This is important for the lower frequencies of Radio, where space is at a premium
4. **Broadcast transmissions:** AM is still widely used for broadcasting on the long, medium and short-wave bands. It is simple to demodulate and this means that radio receivers capable of demodulating amplitude modulation are cheap and simple to manufacture. Nevertheless, many people are moving to high quality forms of transmission like frequency modulation, FM or digital transmissions.
5. **Air band radio:** VHF transmissions for many airborne applications still use AM. It is used for ground to air radio communications as well as two-way radio links for ground staff as well.
6. **Single sideband:** Amplitude modulation in the form of single sideband is still used for HF radio links. Using a lower bandwidth and providing more effective use of the transmitted power this form of modulation is still used for many point to point HF links.
7. **Quadrature amplitude modulation:** AM is widely used for the transmission of data in everything from short range wireless links such as Wi-Fi to cellular telecommunications and much more. Effectively it is formed by having two carriers 90° out of phase.

DOUBLE SIDE BAND MODULATION: GENERATION AND DETECTION	EXPT. NO: 2
	DATE:

1. AIM:

To generate modulated and demodulate DSB-SC Signal for different modulation indices and plot the corresponding waveforms and their spectrum.

2. COMPONENTS & TOOLS REQUIRED:

2. 1. Audio signal generator
2. 2. Carrier generator
2. 3. Balanced modulator Trainer Kit
2. 4. Cathode Ray Oscilloscope.
- 2.5. Connecting wires

3. THEORY:

Balance modulator is used for generation of double side band suppress carrier signal. The output of balanced modulator is equal to the product of applied input signals. In order to generate this, it uses the non-linear characteristics of semiconductor device. Since the carrier does not convey any information, transmitting the carrier along with side band is only wasting of transmission power; therefore, carrier is suppressed before transmission. By doing suppression 67% of transmission power can be saved. The method of transmission of modulated wave without carrier is DSBSC signal.

Balance modulator is also used in generation of SSB signals. The modulated signal undergoes a phase reversal whenever the base band signal crosses zero. Unlike AM, The envelope of DSBSC is different from base band signal. The ring modulator is another circuit for generating the DSBSC signal.

4. BLOCK DIAGRAM:

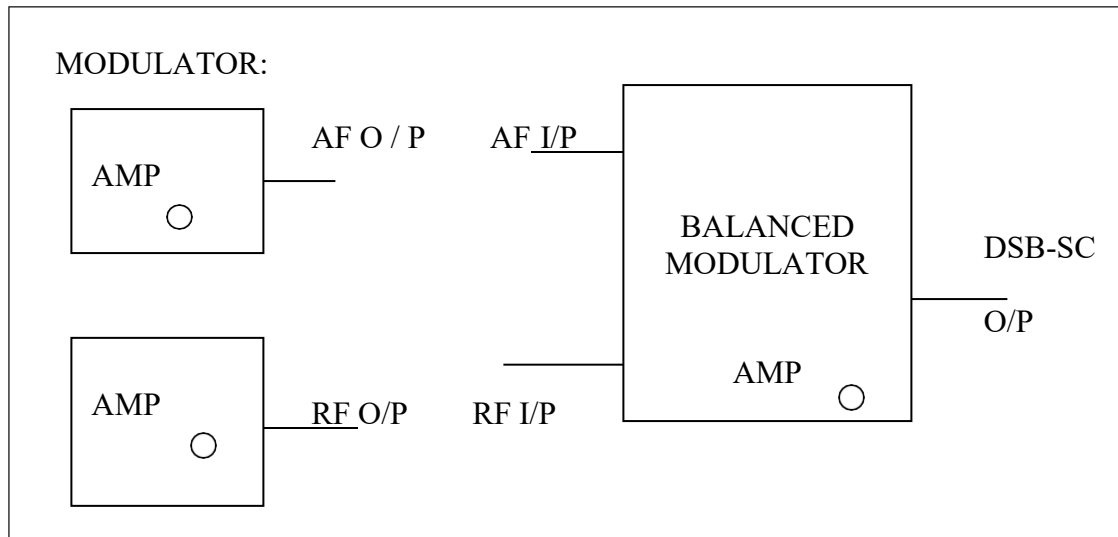

5. MODEL WAVEFORMS:

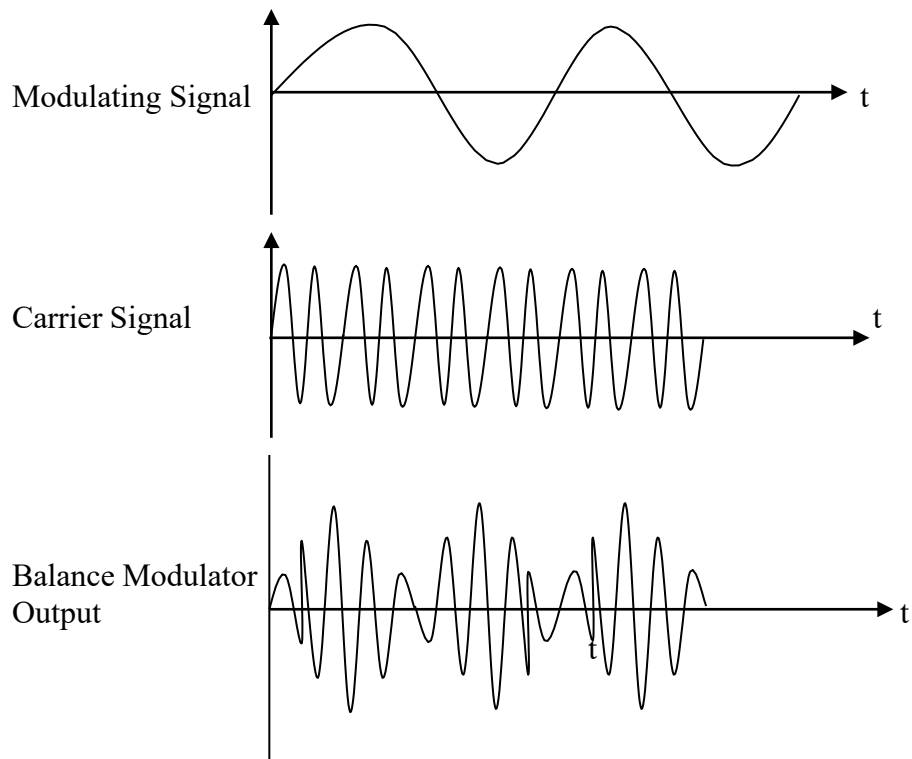

6. EXPERIMENTAL PROCEDURE:

1. Switch on the power supply through mains card.
2. As the circuitry is already wired, you just have to trace the circuit according to the circuit diagram.
3. Connect 5 KHz sinusoidal signal to both the carrier and modulation inputs.
4. Observe the output on CRO and adjust the null potentiometer until the output is 10 KHz sinusoidal wave. Note that this is very sensitive adjustment because you are making the biasing at both inputs exactly the same to get the multiplying effect of the device.
5. Apply a 100 KHz, 0.1v – peak sinusoidal wave to the carrier input and a 5 KHz sinusoidal wave with 0.1v peak to the modulation input.
6. Adjust carrier null potentiometer to obtain a DSBSC wave as output Vary the amplitude frequency of the message signals at different levels.
7. Observe the variation in side bands and suppression of carrier.
8. Record the exact frequency levels of side bands suppressed carrier from CRO.

7. PRECAUTIONS:

1. Check for loose contacts of wires and components.
2. Keep all the control knobs in the minimum position.
3. Before switch on the power supply get the circuit connections verified by the teacher.
4. Adjust the control knobs smoothly.
5. After taking the readings bring back all the control knobs to minimum position.
6. Switch off the power supply before leaving the experimental table.

8. Observations:

1. Amplitude of modulating signal -----
2. Frequency of modulating signal-----
3. Amplitude of carrier signal -----
4. Frequency of carrier signal -----
5. 8.5 Frequency of Balanced detector output signal-----

SOFTWARE PROGRAM

AIM:

To generate DSBSC wave Modulation using SCILAB/MATLAB Software.

APPARATUS REQUIRED:

1. Computer
2. SCILAB/MATLAB software

PROGRAM:

```
t=0:0.000001:.001;
Vm= 1;
Vc= 1;
fm = 2000;
fc= 50000;
m_t = Vm*sin(2*pi*fm*t);
subplot(4,1,1);
plot(t,m_t);
c_t = Vc*sin(2*pi*fc*t);
subplot(4,1,2);
plot(t,c_t);
subplot(4,1,3);
s_t = m_t.*c_t;
hold on;
plot(t,s_t);
plot(t,m_t,'r');
plot(t,-m_t,'r');
hold off;
r = s_t.*c_t;
[b a] = butter(1,0.01);
mr= filter(b,a,r);
subplot(4,1,4);
plot(t,mr);
```

Simulated Wave forms

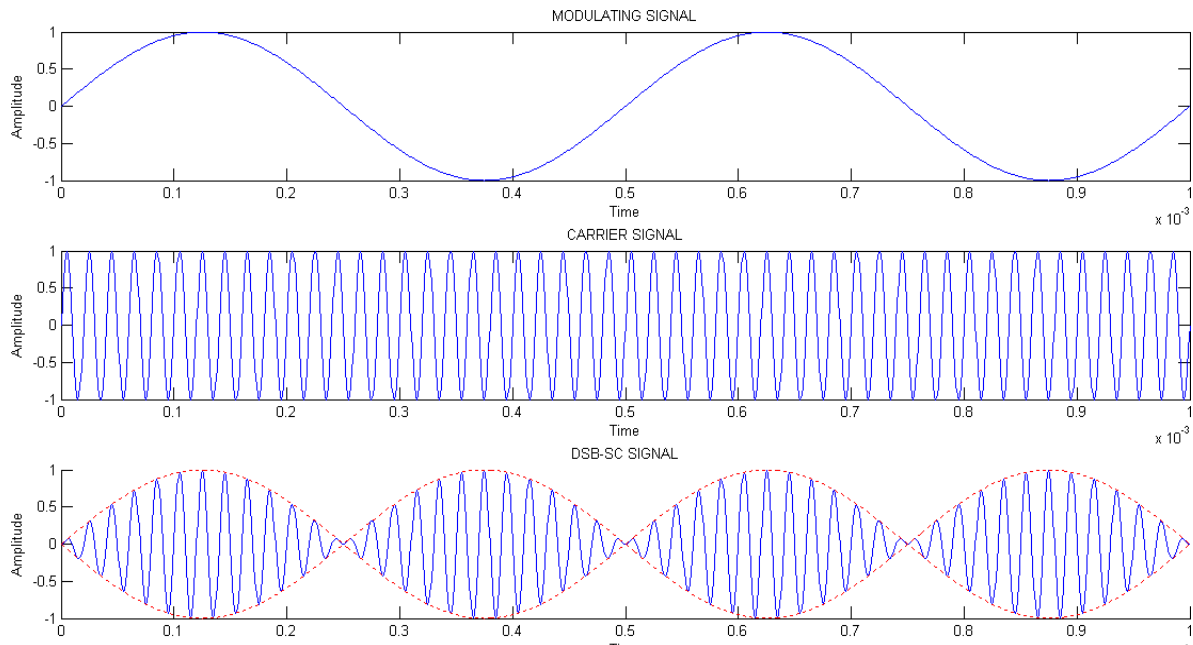

INFERENCE:

DSB-SC modulated wave is observed using MATLAB software.

EXERCISE:

- 1) Generate DSBSC wave with message as $3\sin(2\pi 5t)$ and carrier $6\sin(200\pi t)$.
- 2) Generate DSBSC wave with message as $3\cos(2\pi 50t + 10)$ and carrier $2\sin(1000\pi t)$
- 3) Generate DSBSC wave with message as $3\sin(100\pi t)$ and carrier $6\sin(20000\pi t)$
- 4) Generate DSBSC wave with message as $3\sin(10\pi t + 5)$ and carrier $6\sin(1000\pi t + 10)$
- 5) Demodulate the DSBSC wave $5[\cos(150t) + \cos(50t)]$
- 6) Demodulate the DSBSC wave $5[\cos(1050t) + \cos(950t)]$
- 7) Generate DSBSC wave with message as $5\sin(2\pi 5t)$ and carrier $10\sin(200\pi t)$.
- 8) Generate DSBSC wave with message as $5\cos(2\pi 50t + 10)$ and carrier $10\sin(1000\pi t)$
- 9) Demodulate the DSBSC wave $4[\cos(150t) + \cos(50t)]$
- 10) Demodulate the DSBSC wave $4[\cos(1050t) + \cos(950t)]$
- 11) Generate DSBSC wave with message as $5\sin(2\pi 5t)$ and carrier $7\sin(200\pi t)$.
- 12) Generate DSBSC wave with message as $10\cos(2\pi 60t + 20)$ and carrier $20\sin(2000\pi t)$
- 13) Generate DSBSC wave with message as $30\sin(500\pi t)$ and carrier $60\sin(30000\pi t)$
- 14) Generate DSBSC wave with message as $5\sin(100\pi t + 10)$ and carrier $6\sin(5000\pi t + 20)$
- 15) Demodulate the DSBSC wave $10[\cos(550t) + \cos(650t)]$
- 16) Demodulate the DSBSC wave $50[\cos(1200t) + \cos(800t)]$
- 17) Generate DSBSC wave with message as $50\sin(2\pi 50t)$ and carrier $10\sin(2000\pi t)$.
- 18) Generate DSBSC wave with message as $5\cos(6\pi 50t + 20)$ and carrier $10\sin(1000\pi t)$
- 19) Demodulate the DSBSC wave $4[\cos(250t) + \cos(150t)]$
- 20) Demodulate the DSBSC wave $4[\cos(1100t) + \cos(900t)]$
- 21) Generate DSBSC wave with message as $15\sin(2\pi 50t)$ and carrier $20\sin(100\pi t)$.
- 22) Generate DSBSC wave with message as $50\cos(2\pi 25t + 15)$ and carrier $10\sin(500\pi t)$
- 23) Demodulate the DSBSC wave $15[\cos(200t) + \cos(100t)]$

24) Demodulate the DSBSC wave $4[\cos(2050t)+\cos(1000t)]$

25) Generate DSBSC wave with message as $50\sin(2\pi 5t)$ and carrier $17\sin(100\pi t)$.

9. CONCLUSION:

The output waveform of balanced modulator is observed and plotted.

10. VIVA-VOCE QUESTIONS:

1. What is the significance of the balanced modulator?
2. What is the disadvantage of DSB-FC?
3. What is the percentage of power saving in DSB-SC over DSB-FC?
4. What is the bandwidth required for the transmission of DSB-SC signals?
5. Which detector is used for detecting the DSB-SC signals?
6. Why there is a phase reversal in DSB-SC wave?
7. Define DSB-SC over AM.
8. Write the power relation equation for DSB-SC?
9. What are the applications of DSB-SC?
10. Write the equation for DSB-SC in Time & Frequency domain?
11. What are the different types of modulations?
12. Define AM, DSB-FC, DSB- SC, SSB, VSB?
13. Give the expression for $m(t)$ & $c(t)$ and $s(t)$ for amplitude modulation?
14. Give the expression for modulation index (μ)?
15. Give the expression for sidebands power P_{SB} , P_{LSB} and P_{USB} ?
16. What is DSB-SC system?
17. What are the drawbacks in DSB-FC/AM?
18. What are the applications of DSB-SC?
19. How much bandwidth is required to transmit AM wave as well as DSB-SB wave?
20. How much power is required to transmit AM wave as well as DSB-SC wave?
21. Give the expression for DSB-SC wave?
22. Draw the spectrum of DSB-SC?
23. What is a balanced modulator (or) product modulator?
24. Give the $S(f)$ expression for DSB-SC?
25. What is the principle used in Balanced modulator for the generation of DSB-sc wave?
26. Draw the block diagram of coherent detector?
27. How can we demodulate the DSB wave using coherent detection?
28. What are the drawbacks in DSB-SC system?
29. Coherent detection is also referred as?

30. What are the methods used for the suppression of carrier wave from the AM wave?
31. What is the percentage of power saving in DSB-SC over DSB-FC?
32. What is the bandwidth required for the transmission of DSB-SC signals?
33. Which detector is used for detecting the DSB-SC signals?
34. Why there is a phase reversal in DSB-SC wave?
35. Define DSB-SC over AM.
36. Write the power relation equation for DSB-SC?
37. What are the applications of DSB-SC?
38. Write the equation for DSB-SC in Time & Frequency domain?
39. What are the different types of modulations?
40. Define AM, DSB-FC, DSB- SC, SSB, VSB?
41. Give the expression for $m(t)$ & $c(t)$ and $s(t)$ for amplitude modulation?
42. Give the expression for modulation index (μ)?
43. Give the expression for sidebands power P_{SB} , P_{LSB} and P_{USB} ?
44. What is DSB-SC system?
45. What are the drawbacks in DSB-FC/AM?
46. What are the applications of DSB-SC?
47. How much bandwidth is required to transmit AM wave as well as DSB-SB wave?
48. How much power is required to transmit AM wave as well as DSB-SC wave?
49. Give the expression for DSB-SC wave?
50. Draw the spectrum of DSB-SC?

12. REAL-TIME APPLICATIONS

1. DSB-SC transmission is a special case of double-sideband reduced carrier transmission. It is used for radio data systems.
2. Analogue TV systems: to transmit color information.
3. For transmitting stereo information in FM sound broadcast at VHF.
4. One important application of DSB is the transmission of color information in a TV signal. CB radio and TV broadcasting.
5. Air traffic control radios - Garage door opens keyless remotes.
6. DSB-SC is a technique used in electronic communication, most commonly for transmitting information via a radio carrier wave.
7. DSB-SC used in stereo transmission of FM radio. - Two way radio communications.

SINGLE MODULATION (PHASE SHIFT METHOD): GENERATION AND DETECTION	EXPT. NO: 3
	DATE:

1. AIM:

To generate and demodulate SSB-SC modulated Signal (Phase Shift Method) for different modulation indices and plot the corresponding waveforms and their spectrum.

2. COMPONENTS & TOOLS REQUIRED:

1. A.F generator
2. R.F generator
3. Balanced modulator-1
4. Balance modulator-2
5. Summer and sub-tractor
6. Synchronous detector
7. CRO

3. THEORY:

AM & DSB-SC both modulation techniques require bandwidth twice of the modulating signal bandwidth. Since, two side bands having the same information. It is possible to recover the base band signal from any one of the side band, so only one side band is enough to give information without any loss of course the carrier is suppressed. Such transmission system is called single side band transmission system. SSB requires transmission bandwidth is equal to modulating signal bandwidth.

The reduced bandwidth also improves the SNR ratio and allows more no of channels in a given frequency. These advantage of SSB results in wide spread of SSB for aircrafts, transonic radio telephones, and mature radio communication systems.

4. BLOCK DIAGRAM:

MODULATOR:

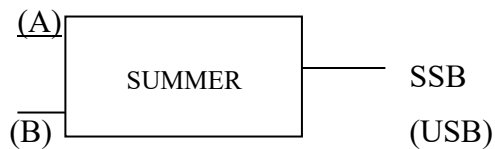
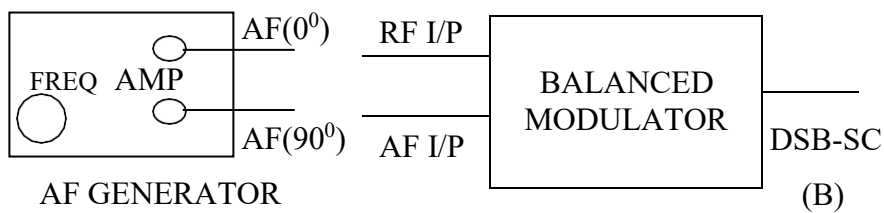
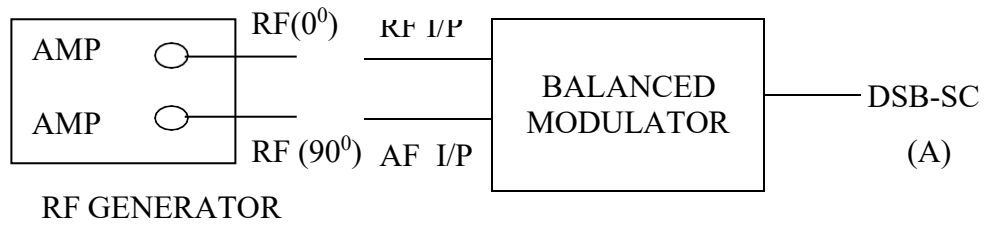

DEMODULATOR:

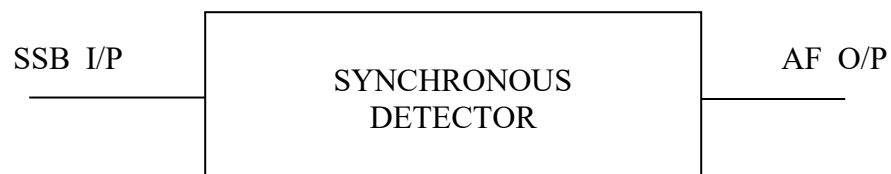

5. MODEL WAVEFORMS

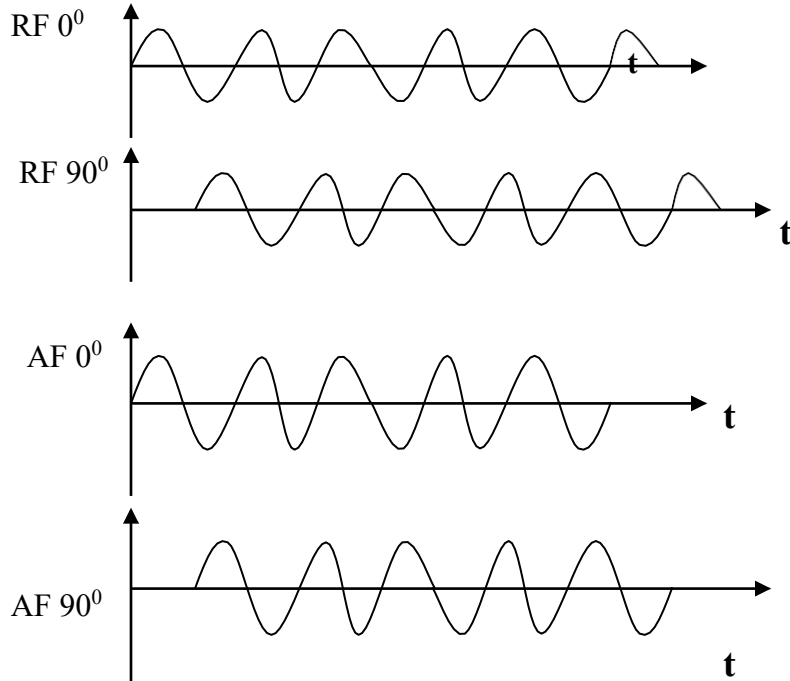

Balanced Modulator o/p - 1

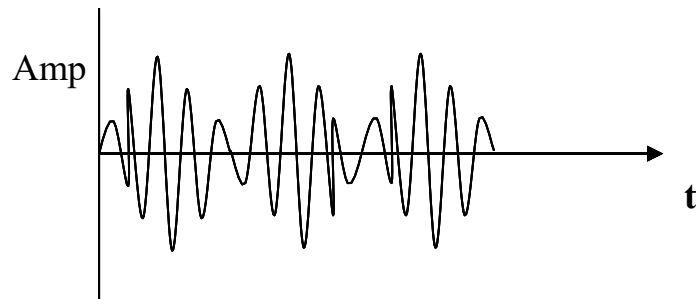

Balanced Modulator o/p - 2

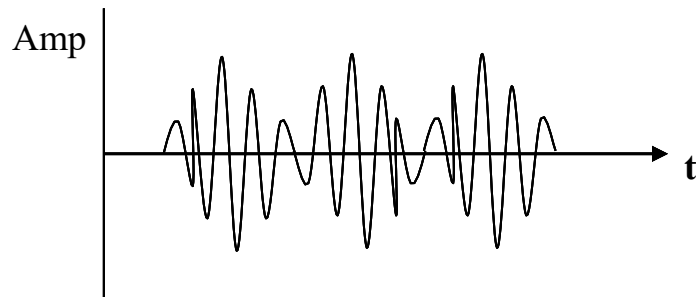

SSB (LSB)

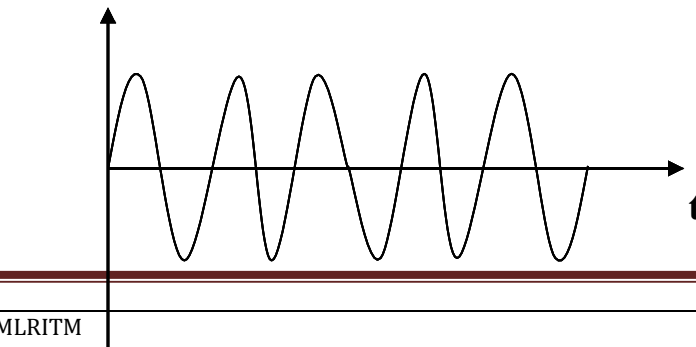

BLOCK DIGRAM DISCRPTION:

1. AF generator: It generates a low frequency (5KHZ) signal using Op-Amp based we in-bridge oscillator. TL-084 is a FET input general purpose Op-Amp integrated circuit.
2. RF generator: Collipit's oscillator-using FET is used here to generate RF signal (100 KHZ frequency) to use as carrier signal. Adjustment for amplitude and frequency are provided.
3. Balanced Modulator: It has been developed using MC 1496 monolithic IC balanced modulator and demodulator. This can be up to 200 KGZ. This modulator is used to generate a DSB – SC signal. A null adjust is provided to suppress the carry.
4. Synchronous Detector: The base band signal can be uniquely recovered from the DSB-SC signal by multiplying with a locally generated sine carrier and then to a low pass filtering the product. The frequency and phase of local oscillator output signal must be equal to carrier signal. This type of coherent demodulation is called Synchronous detection. For demodulation also MC 1496 is used.

6. EXPERIMENTAL PROCEDURE:

1. Switch on the power supply through mains card.
2. As the circuitry is already wired, you just have to trace the circuit according to the circuit diagram.
3. Observe the output of the RF generator using CRO. Available two outputs of RF generator, one is 90° phase shift with other output of RF generator. The o/p frequency is set to 1000 KHZ and 0.1Vpp.
4. Similarly, there are two o/p's available for AF generator also. One is direct output anotherone is 90° phase shift with direct output. Switch is provided to select 2k/4k/6kHz. AGC potentiometer is also provided for gain adjustment set the amplitude to 10Vpp.
5. Connect 0' phase shift RF generator output and 90° phase shift AF generator o/p are to a balanced modulator and reaming two o/p's are connected to other balanced modulator.
6. Observe the both balanced modulator outputs simultaneously on the CRO and adjust the balance control until you get the DSBSC wave on CRO. To get the SSB (LSB) signal connect balance modulator outputs to subs tractor and note down the frequency of SSB wave and compare this with theoretical value.

$$\begin{aligned} \text{SSB (LSB)} &= \text{RF frequency} - \text{AF Frequency} \\ &= 100\text{KHZ} - 2 \text{ KHZ} \\ &= 98\text{KHZ} \end{aligned}$$

- To get the SSB (USB) signal connect balanced modulator outputs to summer and note down the frequency of SSB wave and compare this with theoretical value

$$\begin{aligned} \text{SSB (USB)} &= \text{RF frequency} + \text{AF Frequency} \\ &= 100\text{KHZ} + 2 \text{ KHZ} \\ &= 102\text{KHZ}. \end{aligned}$$

- Connect the SSB signal from summer or subtractor to SSB signal input of synchronous detector and RF signal to the RF input of the synchronous detector.
- Observe the detector output, which is replica of modulating signal (AF signal).
- Repeat all the steps for different frequencies of AF signals.

7. PRECAUTIONS:

- Check for loose contacts of wires and components.
- Keep all the control knobs in the minimum position.
- Before switch on the power supply get the circuit connections verified by the teacher.
- Adjust the control knobs smoothly.
- After taking the readings bring back all the control knobs to minimum position.
- Switch off the power supply before leaving the experimental table.

8. OBSERVATIONS:

- Amplitude of AF Gr 0^0 phase signal = V.
- Frequency of AF Gr 0^0 phase signal = HZ.
- Amplitude of AF Gr 90^0 phase signal = V.
- Frequency of AF Gr 90^0 phase signal = HZ.
- Amplitude of RF Gr 0^0 phase signal = V.
- Frequency of RF Gr 0^0 phase signal = HZ.
- Amplitude of RF Gr 90^0 phase signal = V.
- Frequency of RF Gr 90^0 phase signal = HZ.
- Amplitude of SSB (USB) signal = v.
- Frequency of SSB (USB) signal = HZ.

SOFTWARE PROGRAM

AIM:

To generate SSBSC wave Modulation using SCILAB/MATLAB Software.

APPARATUS REQUIRED:

1. Computer
2. SCILAB/MATLAB

PROGRAM:

```
s=8000;
fm=20;
fc=50;
Am=1;
Ac=1;
t=[0:.1*fs]/fs;
subplot(4,2,1);
m1=Am*cos(2*pi*fm*t);
plot(t,m1);
title('Message Signal');
m2=Am*sin(2*pi*fm*t);
subplot(4,2,2)
c1=Ac*cos(2*pi*fc*t);
plot(t,c1)
title('Carrier Signal');
c2=Ac*sin(2*pi*fc*t);
subplot(4,2,3)
Susb=0.5*m1.*c1-0.5*m2.*c2;
plot(t,Susb);
title('SSB-SC Signal with USB');
subplot(4,2,4);
Slsb=0.5*m1.*c1+0.5*m2.*c2;
plot(t,Slsb);
title('SSB-SC Signal with LSB');
r = Susb.*c1;
[b a] = butter(1,0.0001);
mr= filter(b,a,r);
subplot(4,2,5);
plot(t,mr);
```

Simulated Wave forms

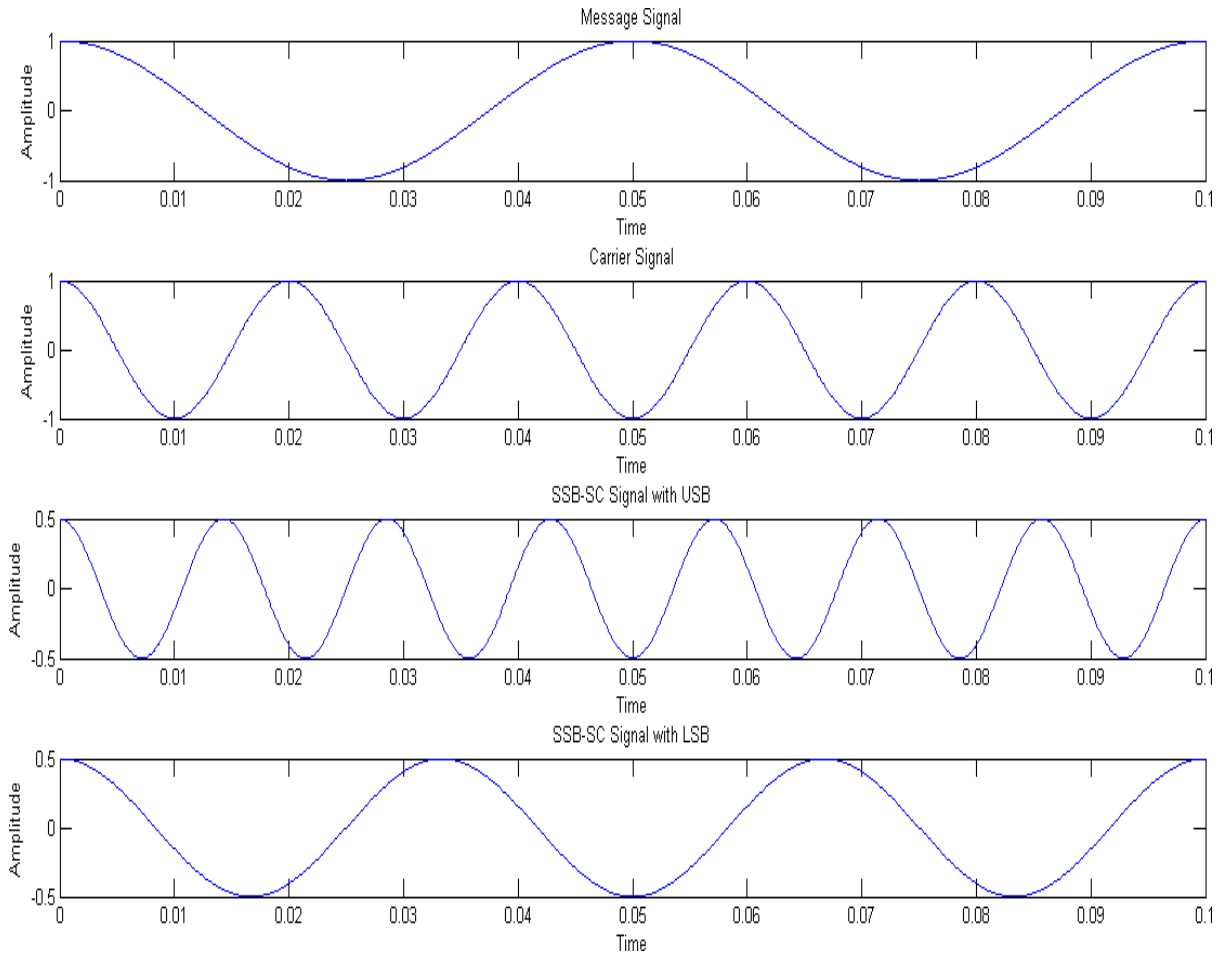

INFERENCE:

The SSBSC wave has been generated by using a MATLAB Software.

EXERCISE:

- 1) Generate a SSB-SC signal with LSB 450 Hz
- 2) Generate a SSB-SC signal with USB 550 Hz
- 3) Generate a SSB-SC signal with LSB 950 Hz
- 4) Generate a SSB-SC signal with USB 1050 Hz
- 5) Generate a SSB-SC signal with LSB 150 Hz
- 6) Generate a SSB-SC signal with USB 250 Hz.
- 7) Generate a SSB-SC signal with LSB 110 Hz
- 8) Generate a SSB-SC signal with USB 650 Hz
- 9) Generate a SSB-SC signal with LSB 850 Hz
- 10) Generate a SSB-SC signal with USB 1150 Hz
- 11) Generate a SSB-SC signal with LSB 650 Hz
- 12) Generate a SSB-SC signal with USB 750 Hz
- 13) Generate a SSB-SC signal with LSB 850 Hz
- 14) Generate a SSB-SC signal with USB 1100 Hz
- 15) Generate a SSB-SC signal with LSB 1200 Hz
- 16) Generate a SSB-SC signal with USB 400 Hz.
- 17) Generate a SSB-SC signal with LSB 100 Hz

- 18) Generate a SSB-SC signal with USB 600 Hz
- 19) Generate a SSB-SC signal with LSB 800 Hz
- 20) Generate a SSB-SC signal with USB 1350 Hz
- 21) Generate a SSB-SC signal with LSB 1000 Hz
- 22) Generate a SSB-SC signal with USB 675 Hz
- 23) Generate a SSB-SC signal with LSB 855 Hz
- 24) Generate a SSB-SC signal with USB 1110 Hz
- 25) Generate a SSB-SC signal with LSB 710 Hz

9. CONCLUSION:

The output waveforms of SSB modulation and de-modulation are observed and plotted.

10. VIVA -VOCE QUESTIONS:

1. What is the use of SSB modulation over DSB-SC modulation?
2. What is the amount of power saving in SSB over DSB-SC?
3. What is the bandwidth of SSB?
4. What is the application of SSB?
5. What are the advantages of SSB over conventional AM and DSB-SC?
6. Write the equation for SSB-SC in Time domain?
7. Define SSB-SC over AM.
8. Write the power relation equation for SSB-SC?
9. What are the Generation and Detection methods of SSB-SC?
10. Write the equation for SSB-SC in Frequency domain?
11. Give the advantages of SSB?
12. What are applications of SSB?
13. What type of methods used for the generation of SSB?
14. Write the time-domain expression for SSB ($S_U(t)$ or $S_L(t)$)?
15. Define Hilbert transform?
16. Give the expression for the envelope of SSB wave?
17. What is VSB modulation?
18. Write applications of VSB modulation?
19. Draw the spectrum of VSB modulation?
20. What is the bandwidth of VSB modulation?
21. Give expression for angle modulation?
22. What is the relation between instantaneous frequency ($f_i(t)$) and phase angle $\theta(t)$ of angle modulation.
23. Draw the spectrum of SSB waves for USB and LSB?

24. Give the advantages of SSB?
25. What are applications of SSB?
26. What type of methods used for the generation of SSB?
27. Write the time-domain expression for SSB ($S_U(t)$ or $S_L(t)$)?
28. What are applications of SSB?
29. What is the principle used in Balanced modulator for the generation of DSB-sc wave?
30. How can we demodulate the DSB wave using coherent detection?
31. What is the application of SSB?
32. What are the advantages of SSB over conventional AM and DSB-SC?
33. Write the equation for SSB-SC in Time domain?
34. Define SSB-SC over AM.
35. Write the power relation equation for SSB-SC?
36. What are the Generation and Detection methods of SSB-SC?
37. Write the equation for SSB-SC in Frequency domain?
38. Give the advantages of SSB?
39. What are applications of SSB?
40. What type of methods used for the generation of SSB?
41. Write the time-domain expression for SSB ($S_U(t)$ or $S_L(t)$)?
42. Define Hilbert transform?
43. Give the expression for the envelope of SSB wave?
44. What is VSB modulation?
45. Write applications of VSB modulation?
46. Draw the spectrum of VSB modulation?
47. What is the bandwidth of VSB modulation?
48. Give expression for angle modulation?
49. What is the relation between instantaneous frequency ($f_i(t)$) and phase angle $\theta(t)$ of angle modulation.
50. Draw the spectrum of SSB waves for USB and LSB?

11. REAL-TIME APPLICATIONS

1. In radio communications, single-sideband modulation (SSB) or single-sideband suppressed-carrier modulation (SSB-SC) is a refinement of amplitude modulation which uses transmitter power and bandwidth more efficiently.
2. SIGLE SIDEBAND MODULATION is used in telephone communication.
3. SSB-SC is used in Frequency Division Multiplexing and Point To Point COMMUNICATION.
4. Analogue TV systems: to transmit color information.
5. For transmitting stereo information in FM sound broadcast at VHF.
6. One important application of DSB is the transmission of color information in a TV signal. -CB radio - TV broadcasting.
7. Air traffic control radios - Garage door opens keyless remotes - DSB-SC is a technique used in electronic communication, most commonly for transmitting information via a radio carrier wave. - DSB-SC used in stereo transmission of FM radio. - Two way radio communications.
8. Television broadcasting...Such as VSB signal. OOhy4 using MATLAB software.
9. Television broadcasting...Such as VSB signal.

1. AIM:

To generate Frequency modulated Signal and perform demodulation for different modulation indices. Plot the corresponding waveforms and their spectrum. Compare the modulation index theoretically and practically. Plot the effect of modulating Signal frequency and Amplitude on the modulation index.

2. COMPONENTS & TOOLS REQUIRED:

- 2. 1. Audio signal generator
- 2. 2. Carrier generator
- 2. 3. Frequency modulator Trainer Kit
- 2. 4. Cathode Ray Oscilloscope (30 MHz).
- 2.5. Connecting wires

3. THEORY:

FM Modulation is a non-linear modulation technique. In FM the frequency of carrier is varied in accordance with amplitude of modulating signal (AF signal). But amplitude is maintained constant. Since the variation in phase angular term it is comes under angle modulation scheme, the most important feature of FM modulation is that it can be provide better discrimination against noise and interference than AM. The disadvantage of FM is it requires more transmission bandwidth than AM and we transmit the FM signals to longer distances.

The quantity K_f represents frequency sensitivity of modulator. Hence $K_f \cdot A_m$ represents the total deviation f . The ratio of max frequency deviation to modulating frequency defines as modulation index, which is given by,

$$\text{Modulation index} = \frac{\text{Max frequency deviation}}{\text{Modulating frequency}}$$

If Modulation index is less than one then the modulated wave is called Narrow Band FM signal. If Modulation index is greater than one then the modulated wave is called Wide Band FM signal.

4. BLOCK DIAGRAM:

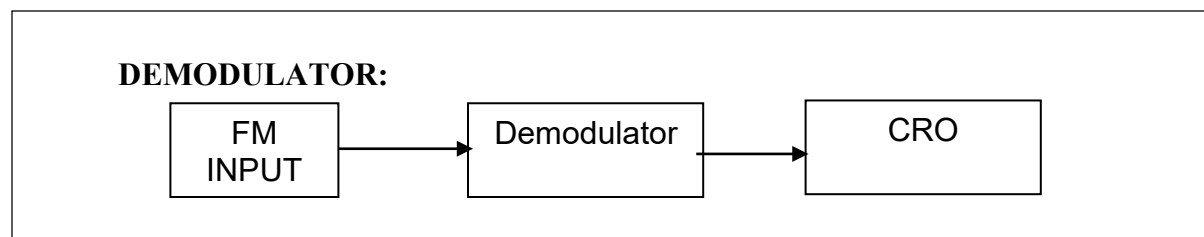
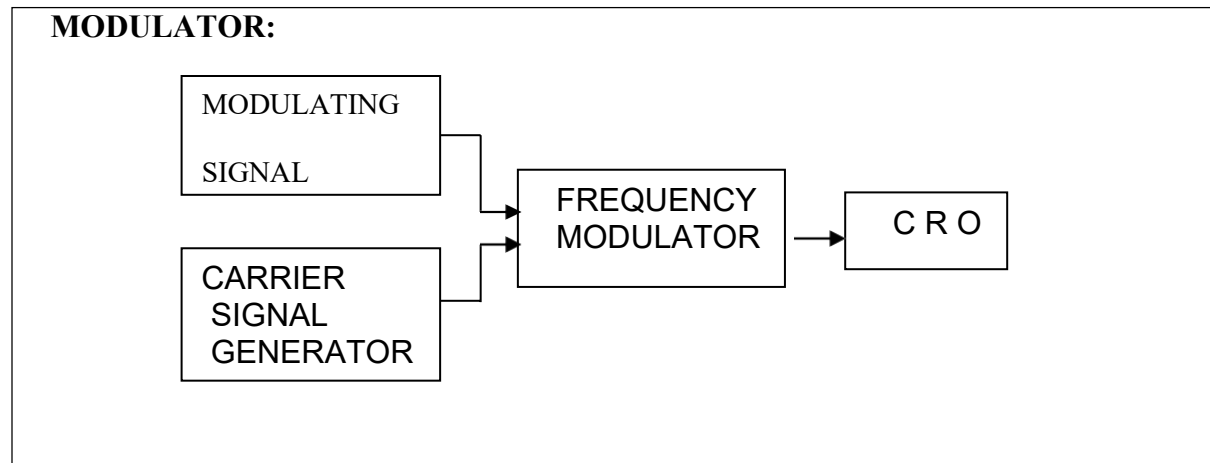

5. MODEL WAVEFORMS:

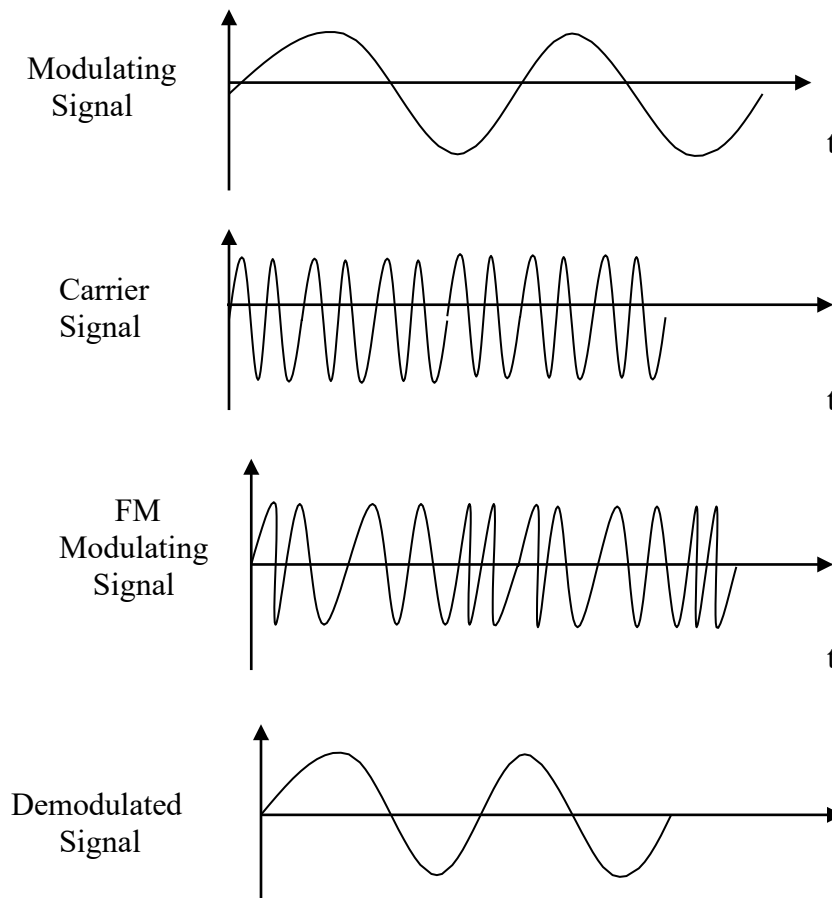

6. EXPERIMENTAL PROCEDURE:

1. Switch on the power supply through mains card.
2. Observe the modulating signal in CRO and set the modulating voltage to 1.2 V and frequency to 10 KHz and note down these values. (Here the carrier is internally generated signal).
3. Connect the modulating signal to modulator also connect the output of Modulator to CRO and note down the waveforms.
4. Find out the maximum and minimum frequency of frequency modulated wave from CRO and note down these values, from these values calculate modulation index by using the above formula.
5. Connect the frequency-modulated signal to the demodulator.
6. Connect the CRO across the output terminals of the demodulator.
7. Observe the waveform of the modulating signal for different modulating indices.

8. PRECAUTIONS:

- 7.1 Check for loose contacts of wires and components.
- 7.2 Keep all the control knobs in the minimum position.
- 7.3 Before switch on the power supply get the circuit connections verified by the teacher.
- 7.4 Adjust the control knobs smoothly.
- 7.5 After taking the readings bring back all the control knobs to minimum position.
- 7.6 Switch off the power supply before leaving the experimental table.

Observations:

- 8.1 Amplitude of modulating signal_____
 - 8.2 Frequency of modulating signal_____
 - 8.3 Amplitude of carrier signal_____
 - 8.4 Frequency of carrier signal_____
 - 8.5 Frequency deviation _____
 - 8.6 Amplitude of demodulating signal_____
 - 8.7 Frequency of demodulating signal_____
-

USING DECRETE COMPONENTS

AIM:

To observe and plot FM modulated wave with $A_m = 5V_{p-p}$.

COMPONENTS & TOOLS REQUIRED:

Component name	Quantity
IC 555 timer -	01
Resistors 1.5K	02
10K	01
Capacitors 0.1uF	01
10uF	01
Diode 1N4007	01
Function generator	01
Cathode ray oscilloscope (30 MHz)	01
CRO probes	03
Regulated power supply	01
Connecting wires	--

THEORY:

FM Modulation is a non-linear modulation technique. In FM the frequency of carrier is varied in accordance with amplitude of modulating signal (AF signal). But amplitude is maintained constant. Since the variation in phase angular term it is comes under angle modulation scheme, the most important feature of FM modulation is that it can be provide better discrimination against noise and interference than AM. The disadvantage of FM is it requires more transmission bandwidth than AM and we transmit the FM signals to longer distances. The quantity K_f represents frequency sensitivity of modulator. Hence $K_f * A_m$ represents the total deviation f . The ratio of max frequency deviation to modulating frequency defines as modulation index, which is given by

$$\text{Modulation index} = \frac{\text{Max frequency deviation}}{\text{Modulating frequency}}$$

If modulation index is less than one then the modulated wave is called Narrow Band FM signal.
If Modulation index is greater than one then the modulated wave is called Wide Band FM signal.

CIRCUIT DIAGRAM:

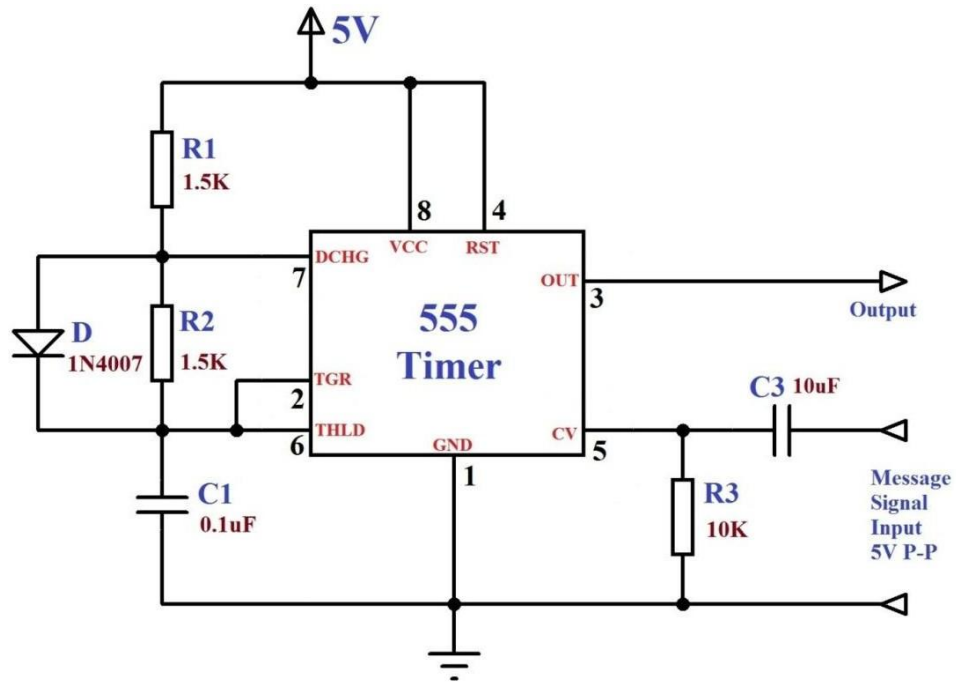

EXPECTED WAVEFORMS:

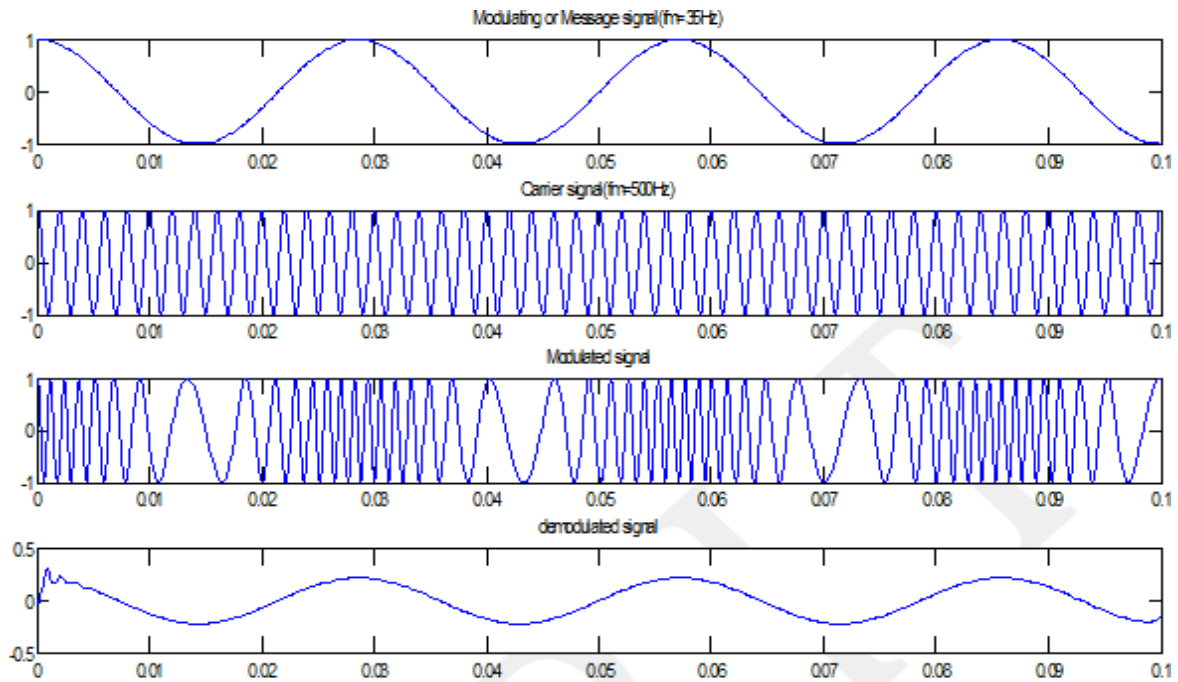

EXPERIMENTAL PROCEDURE:

- ❖ Connect the circuit as per the circuit diagram.
- ❖ Generate the modulating signal from the function generator with an amplitude of $5 V_{P-P}$, with a frequency of 10KHz & Observe the modulating signal in CRO and apply it to pin5 of IC 555 Timer as message signal.
- ❖ Observe the modulated waveform in CRO at pin3 of IC 555 Timer.
- ❖ Find out the maximum and minimum frequency of frequency modulated wave from CRO and note down these values, from these values calculate modulation index by using the above formula.

PRECAUTIONS:

- ❖ Check for loose contacts of wires and components.
- ❖ Keep all the control knobs in the minimum position.
- ❖ Before switch on the power supply get the circuit connections verified by the teacher.
- ❖ After taking the readings bring back all the control knobs to minimum position.
- ❖ Switch off the power supply before leaving the experimental table.

Results:

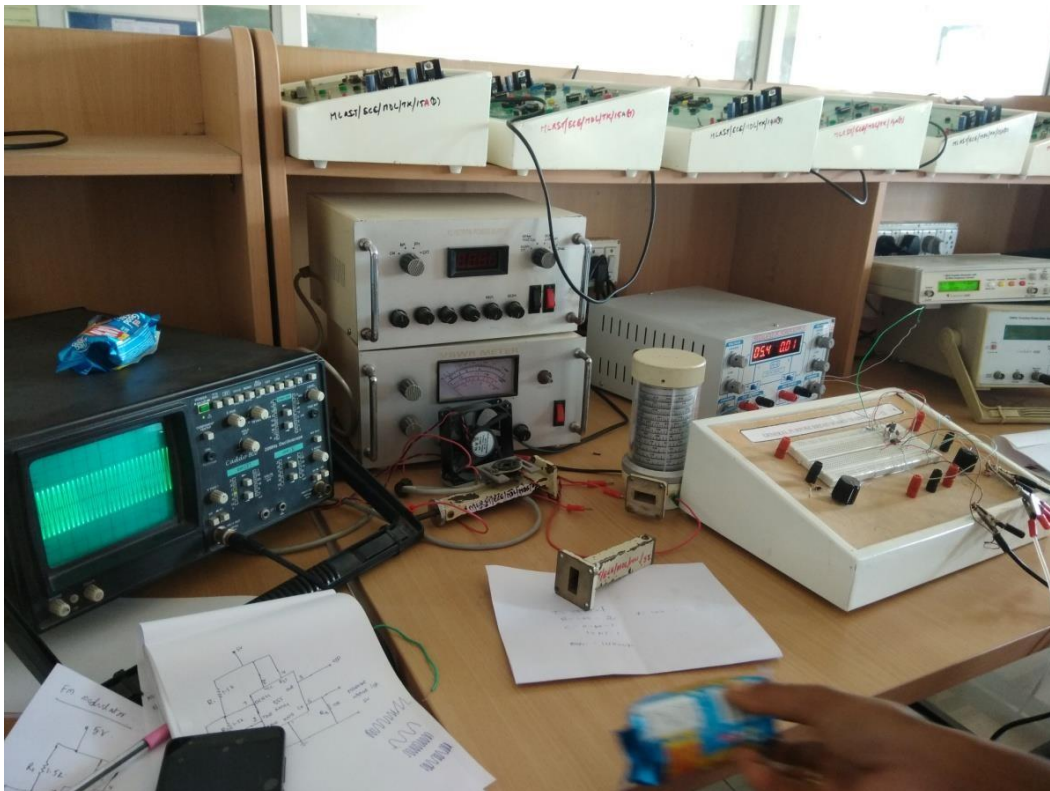

SOFTWARE PROGRAM

AIM:

To generate FM wave Modulation using SCILAB/MATLAB Software.

APPARATUS REQUIRED:

1. Computer
2. SCILAB/MATLAB

PROGRAM:

%The frequency modulation(FM)waveform in time and frequency domain.

%fm=35HZ,fc=500HZ,Am=1V,Ac=1V,B=10

fs=10000;

Ac=1;

Am=1;

fm=35;

fc=500;

B=10;

t=(0:.1*fs)/fs;

wc=2*pi*fc;

wm=2*pi*fm;

m_t=Am*cos(wm*t);

subplot(5,1,1);

plot(t,m_t);

title('Modulating or Message signal(fm=35Hz)');

c_t=Ac*cos(wc*t);

subplot(5,1,2);

plot(t,c_t);

title('Carrier signal(fm=500Hz)');

s_t=Ac*cos((wc*t)+B*sin(wm*t));

subplot(5,1,3);

plot(t,s_t);

title('Modulated signal');

```

d=demod(s_t,fc,fs,'fm');
subplot(5,1,4);
plot(t,d);
title('demodulated signal');

```

Simulated Wave forms

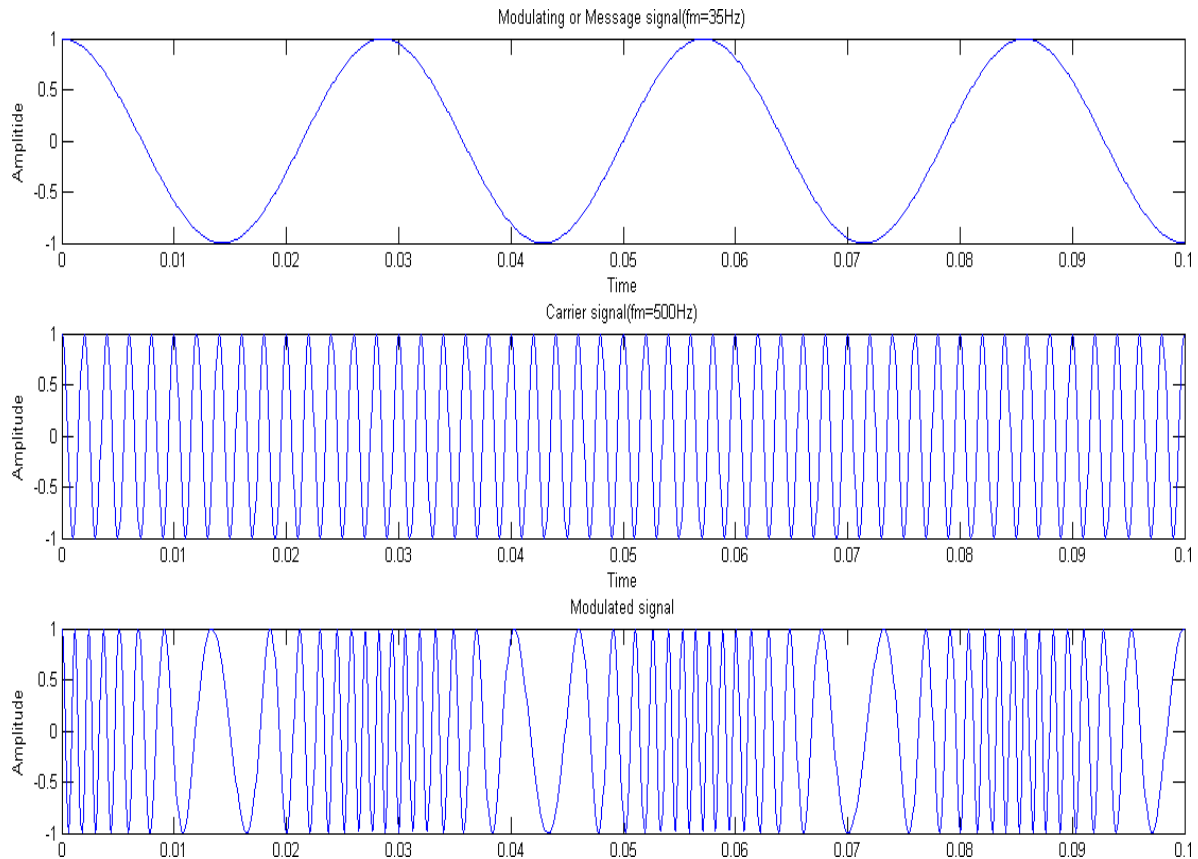

INFERENCE:

The FM wave has been generated by using a MATLAB Software.

EXERCISE:

- 1) Generate an FM signal with $\Delta f=20\text{Khz}$
- 2) Generate a FM signal when message input is a square wave and carrier is a sinusoidal waveform.
- 3) Generate a FM signal when message input is a sinusoidal wave and carrier is a square waveform.
- 4) Generate an FM signal with $\Delta f=10\text{Khz}$
- 5) Generate an FM signal with $\Delta f=100\text{Khz}$
- 6) Generate an FM signal with $\Delta f=50\text{Khz}$
- 7) Generate an FM signal with $\Delta f=300\text{Khz}$
- 8) Generate an FM signal with $\Delta f=90\text{Khz}$
- 9) Generate an FM signal with $\Delta f=400\text{Khz}$
- 10) Generate an FM signal with $\Delta f=700\text{Khz}$

- 11) Generate an FM signal with $\Delta f=30\text{Khz}$
- 12) Generate a FM signal when message input is a sinusoidal wave and carrier is a triangular waveform.
- 13) Generate a FM signal when message input is a triangular wave and carrier is a square waveform.
- 14) Generate an FM signal with $\Delta f=40\text{Khz}$
- 15) Generate an FM signal with $\Delta f=200\text{Khz}$
- 16) Generate an FM signal with $\Delta f=150\text{Khz}$
- 17) Generate an FM signal with $\Delta f=250\text{Khz}$
- 18) Generate an FM signal with $\Delta f=90\text{Khz}$
- 19) Generate an FM signal with $\Delta f=420\text{Khz}$
- 20) Generate an FM signal with $\Delta f=70\text{KhZ}$
- 21) Generate an FM signal with $\Delta f=1000\text{KhZ}$
- 22) Generate an FM signal with $\Delta f=300\text{Khz}$
- 23) Generate a FM signal when message input is a sinusoidal wave and carrier is a rectangular waveform.
- 24) Generate a FM signal when message input is a triangular wave and carrier is a sine waveform.
- 25) Generate an FM signal with $\Delta f=410\text{Khz}$

9. CONCLUSION:

The output waveforms of frequency modulation are observed for modulation index less than one and greater than one. Also demodulation is verified.

10. VIVA -VOCE QUESTIONS:

1. What is frequency modulation?
2. How the FM can be differentiated from the frequency translation?
3. In Frequency modulated waveform where does the message signal exist?
4. What is meant by carrier nulls?
5. What is the bandwidth required for NBFM?
6. What is the bandwidth required for WBFM?
7. Generate FM wave using PM modulator?
8. Generate FM wave using PM modulator?
9. Define Frequency Deviation. What is practical Frequency Deviation value for FM broadcasting?
10. Write the equation for FM and PM waves?

11. What is the relation between instantaneous frequency ($f_i(t)$) and phase angle $\theta(t)$ of angle modulation.
12. Give expression for the FM wave as well as PM wave?
13. Draw the block diagram of FM wave using PM wave?
14. Draw the block diagram of PM wave using FM wave?
15. Draw the waveform of FM and PM waves?
16. Define modulation index (β) of the FM wave?
17. Give the expression for β and Δf (frequency deviation)?
18. What is the practical and theoretical bandwidth of FM wave?
19. What is Carson's rule?
20. Compare narrow and wideband FM?
21. Define deviation ratio and constant average power?
22. Draw the spectrum of FM modulation?
23. What is PLL (phase locked loop) and what are the basic components used in PLL for the detection of FM waves?
24. What are the types of noise?
25. Define Noise Figure (or figure of merit)?
26. Define Signal to noise (SNR) ratio?
27. Define (SNR) I/p and (SNR) O/p and (SNR) channel ?
28. Write the figure of merit equation for DSB-SC, SSB-SC and FM?
29. Write the figure of merit of FM receiver?
30. Define Pre-emphasis and De-emphasis in FM?

11. REAL-TIME APPLICATIONS

1. Frequency modulation is widely used for FM radio broadcasting. It is also used in telemetry, radar, seismic prospecting, and monitoring newborns for seizures via EEG, two-way radio systems, music synthesis, magnetic tape-recording systems and some video-transmission systems
2. FM is also used at audio frequencies to synthesize sound. This technique, known as FM synthesis was popularized by early digital synthesizers and became a standard feature in several generations of personal computer sound cards.
3. FM signal can also be used to carry a stereo signal this is done with multiplexing and demultiplexing before and after the FM process. The FM modulation and demodulation

process is identical in stereo and monaural processes. A high-efficiency radio-frequency switching amplifier can be used to transmit FM signals (and other constant-amplitude signals).

4. For a given signal strength (measured at the receiver antenna), switching amplifiers use less battery power and typically cost less than a linear amplifier. This gives FM another advantage over other modulation methods requiring linear amplifiers, such as AM and QAM.
5. FM is commonly used at VHF radio frequencies for high-fidelity broadcasts of music and speech. Analog TV sound is also broadcast using FM. Narrowband FM is used for voice communications in commercial and amateur radio settings.

In broadcast services, where audio fidelity is important, wideband FM is generally used. In two-way radio, narrowband FM (NBFM) is used to conserve bandwidth for land mobile, marine mobile and other

1. AIM:

To study the spectrum of AM signals using spectrum analyzer.

2. COMPONENTS & TOOLS REQUIRED:

- 2.1 Spectrum Analyzer.
- 2.2 Function generator.
- 2.3 AM Wave generators

3. THEORY:**3.1. INTRODUCTION TO SPECTRUM ANALYSER:**

The analyzer of electrical signals is a fundamental problem for many Engineers and scientists.

The traditional ways of observing the electrical signal is in time domain by using oscilloscope. The time domain is used to recover relative timing and phase information which is used to characterize electric circuit behavior .

But practically some circuits like Amplifiers, Filters, Oscillators, Modulators, Mixers etc,. Requires frequency domain analysis. This frequency domain analysis can be easily studied in using Spectrum analyzer. It graphically displays voltage or power function of frequency on a circuit.

Basically two types of spectrum analyzer are available. They are

- 1. Swept – tuned
- 2. Real – time

The HM5010 is the swept – tuned Spectrum analyzer. This spectrum analyzer permits the detection of spectrum components of electrical signal in the frequency range of 0.15MHz to1050 MHz. In the oscilloscope the amplitude is displayed on the time domain and in spectrum analyzer it will be displayed in frequency domain.

3.2. ADVANTAGES OF SPECTRUM ANALYZER:

- 3.2.1 Spectrum analyzer is used to observe the difference fill characteristics.
- 3.2.2 It used to observe the Modulated wave from spectrum

3.2.3 It is used to observe the Noise level in the transmission

Ex: In CATV

3.3. CONTROL ELEMENTS:

3.3.1. MARKER ON / OFF:

When the marker push button is set to the off position the CF indicator is lit and display shows the center frequency. When the switch is in the ON position 1 MHz the display shows the marker frequency. The marker shows on the screen a sharp peak the marker frequency is adjustable by means of the marker knob and can be aligned with a spectral line.

NOTE: Switch off the marker before taking correct amplitude reading.

3.3.2. CF / MK: (CENTER FREQUENCY / MARKER)

The CF LED is lit when the digital display shows the center frequency. The center frequency is the frequency, which is displayed in the horizontal center of the CRT. The MK LED is lit when the marker pushbutton is in the ON position. The digital display shows the marker frequency in the case.

3.3.3. DIGITAL DISPLAY: (DISPLAY OF CENTER FREQUENCY / MARKER FREQUENCY):

SIGM: Display with 100 KHz resolution.

UNCAL: Blinking of this LED indicates incorrectly displayed amplitude values. This is to scan width and filter setting combinations which give to low amplitude readings because the IF filters have not being settled. This may occur when the scanned frequency range is too large compared to the IF bandwidth (20 KHz) and or the video filter bandwidth (4 KHz). Measurements in the case can either be taken with out a video filter or the scan width has to be decreased

CENTER FREQUENCY: COURSE / FINE:

Both rotary knobs are used for center frequency setting. The center frequency is displayed at the horizontal center of the screen.

BAND WIDTH: Selects between 400 KHz. If a bandwidth of 20 KHz is selected the noise level decreases and the selectivity is improved spectral lines which are relatively close together can be distinguished. As the small signal transient

response amplitude values if the scan width is set at too wide a frequency span. The uncial LED will indicate this condition.

SCAN WIDTH: The scan width selectors control the scan width per division of the horizontal axis. The frequency / Div can be increased by means of the > button and decreased by means of the < button. The width of the scan range is displayed in MHz / Div and refers to each horizontal division on the graticule the center frequency is indicated by the vertical line at middle of the horizontal axis. The frequency decreased to the left in a similar way. In this case the left graticule line corresponds to 0 Hz with these settings a spectral line is visible which is referred to as zero frequency. Spectral lines displayed left of the zero frequency point are so called image frequency. In the zero scan made the spectrum analyzer operates like a receiver with selectable band width. The frequency is selected via the center frequency .The selected scan width / div settings are indicated by a number of LEDs above the range setting puss buttons.

3.4 APPLICATIONS:

- 3.4.1 The spectrum analyzer is useful for observing the amplitude modulation frequency, modulation frequency spectrum.
- 3.4.2. It is useful in measuring low level modulation.
- 3.4.3. It is used in measuring carrier frequency and modulation level.

4. MODEL WAVEFORMS:

AM Spectral Analysis Signal:

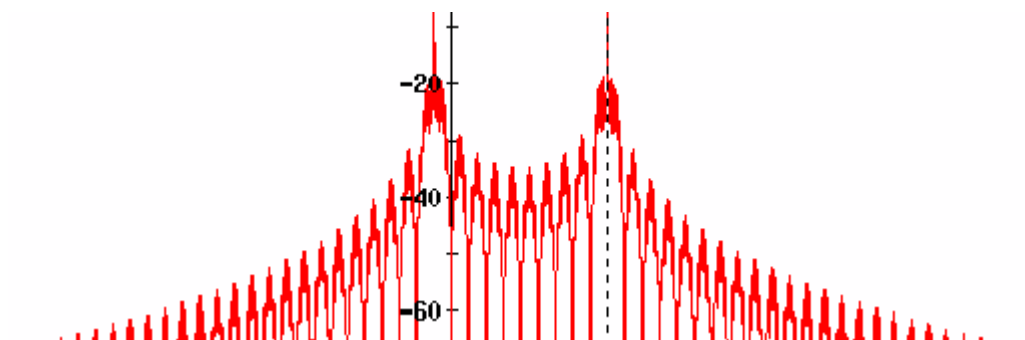

5. PRECAUTIONS:

- 5.1 Check for loose contacts of wires and components.
- 5.2 Keep all the control knobs in the minimum position.

- 5.3 Before switch on the power supply get the circuit connections verified by the teacher.
- 5.4 Adjust the control knobs smoothly.
- 5.5 After taking the readings bring back all the control knobs to minimum position.
- 5.6 Switch off the power supply before leaving the experimental table.

6. CONCLUSION:

The spectrum of AM Signals are observed using spectrum analyzer and plotted.

7. VIVA -VOCE QUESTIONS:

- 7.1 Define a spectrum?
- 7.2 Is it possible to visualize the time domain signals using spectrum analyzer?
- 7.3 How can we select the central frequency?
- 7.4 How many side bands appear for a conventional AM signal?
- 7.5 What are the major components required to apply the AM signals to the spectrum analyzer?
- 7.6 Define a marker?
- 7.7 Is it possible to visualize the time domain signals using spectrum analyzer?
- 7.8 Draw the Spectrum of AM wave?
- 7.9 Draw the Spectrum of DSB and SSB wave?
- 7.10 What are frequencies components present in AM wave?
- 7.11 What are the major components required to apply the AM signals to the spectrum analyzer?
- 7.12 Give the expression for sidebands power P_{SB} , P_{LSB} and P_{USB} ?
- 7.13 Write the modulation index in terms of total power and carrier power?
- 7.14 Draw the spectrum of DSB-SC?
- 7.15 Give the $S(f)$ expression for DSB-SC?
- 7.16 What are the methods used for the suppression of carrier wave from the AM wave?
- 7.17 Draw the spectrum of SSB waves for USB and LSB?
- 7.18 What is the relation between instantaneous frequency ($f_i(t)$) and phase angle $\theta(t)$ of angle modulation.
- 7.19 What is the need for communication?
- 7.20 Define deviation ratio and constant average power?

- 7.21 Is it possible to visualize the time domain signals using spectrum analyzer?
- 7.22 How can we select the central frequency?
- 7.23 How many side bands appear for a conventional AM signal?
- 7.24 Give the expression for sidebands power P_{SB} , P_{LSB} and P_{USB} ?
- 7.25 Write the modulation index in terms of total power and carrier power?
- 7.26 Draw the spectrum of DSB-SC?
- 7.27 Give the $S(f)$ expression for DSB-SC?
- 7.28 What are the methods used for the suppression of carrier wave from the AM wave?
- 7.29 Define Signal to noise (SNR) ratio?
- 7.30 Compare narrow and wideband FM?

1. AIM:

To study the spectrum of FM signals using spectrum analyzer.

2. COMPONENTS & TOOLS REQUIRED:

2.1 Spectrum Analyzer.

2.2 Function generator.

2.3 AM Wave generators

3. THEORY:**3.1. INTRODUCTION TO SPECTRUM ANALYSER:**

The analyzer of electrical signals is a fundamental problems for many Engineers and scientists.

The traditional ways of observing the electrical signal is in time domain by using oscilloscope. The time domain is used to recover relative timing and phase information which is used to characterize electric circuit behavior.

But practically some circuits like Amplifiers, Filters, Oscillators, Modulators, Mixers etc., Requires frequency domain analysis. This frequency domain analysis can be easily studied in using Spectrum analyzer. It graphically displays voltage or power function of frequency on a circuit.

Basically two types of spectrum analyzer are available. They are

3. Swept – tuned

4. Real – time

The HM5010 is the swept – tuned Spectrum analyzer. This spectrum analyzer permits the detection of spectrum components of electrical signal in the frequency range of 0.15MHz to1050 MHz In the oscilloscope the amplitude is displayed on the time domain and in spectrum analyzer it will be displayed in frequency domain.

3.2. ADVANTAGES OF SPECTRUM ANALYZER:

3.2.4 Spectrum analyzer is used to observe the difference fill characteristics.

3.2.5 It used to observe the Modulated wave from spectrum

3.2.6 It is used to observe the Noise level in the transmission

Ex: In CATV

3.3. CONTROL ELEMENTS:

3.3.1. MARKER ON / OFF:

When the marker push button is set to the off position the CF indicator is lit and display shows the center frequency. When the switch is in the ON position 1 MHz the display shows the marker frequency. The marker shows on the screen a sharp peak the marker frequency is adjustable by means of the marker knob and can be aligned with a spectral line.

NOTE: Switch off the marker before taking correct amplitude reading.

3.3.2. CF / MK: (CENTER FREQUENCY / MARKER)

The CF LED is lit when the digital display shows the center frequency. The center frequency is the frequency, which is displayed in the horizontal center of the CRT. The MK LED is lit when the marker pushbutton is in the ON position. The digital display shows the marker frequency in the case.

3.3.3. DIGITAL DISPLAY: (DISPLAY OF CENTER FREQUENCY / MARKER FREQUENCY):

SIGM: Display with 100 KHz resolution.

UNCAL: Blinking of this LED indicates incorrectly displayed amplitude values. This is to scan width and filter setting combinations which give to low amplitude readings because the IF filters have not being settled. This may occur when the scanned frequency range is too large compared to the IF bandwidth (20 KHz) and or the video filter bandwidth (4KHz). Measurements in the case can either be taken without a video filter or the scan width has to be decreased

CENTER FREQUENCY: COARSE / FINE:

Both rotary knobs are used for center frequency setting. The center frequency is displayed at the horizontal center of the screen.

BAND WIDTH: Selects between 400 KHz. If a bandwidth of 20 KHz is selected the noise level decreases and the selectivity is improved spectral lines which are relatively close together can be distinguished. As the small signal transient response amplitude values if the scan width is set at too wide a frequency span.

The uncial LED will indicate this condition.

SCAN WIDTH: The scan width selectors control the scan width per division of the horizontal axis. The frequency / Div can be increased by means of the > button and decreased by means of the < button.

The width of the scan range is displayed in MHz / Div and refers to each horizontal division on the graticule the center frequency is indicated by the vertical line at middle of the horizontal axis. The frequency decreased to the left in a similar way. In this case the left graticule line corresponds to 0 Hz with these settings a spectral line is visible which is referred to as zero frequency. Spectral lines displayed left of the zero frequency point are so called image frequency. In the zero scan made the spectrum analyzer operates like a receiver with selectable bandwidth. The frequency is selected via the center frequency. The selected scan width / div settings are indicated by a number of LEDs above the range setting push buttons.

3.4 APPLICATIONS:

- 3.4.1 The spectrum analyzer is useful for observing the amplitude modulation frequency, modulation frequency spectrum.
- 3.4.4. It is useful in measuring low level modulation.
- 3.4.5. It is used in measuring carrier frequency and modulation level.

4. MODEL WAVEFORMS:

FM Spectral Analysis Signal:

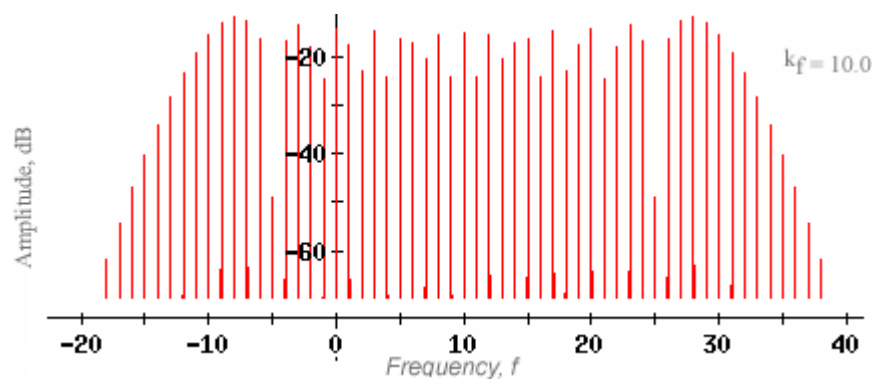

5. PRECAUTIONS:

- 5.1 Check for loose contacts of wires and components.
- 5.2 Keep all the control knobs in the minimum position.
- 5.3 Before switch on the power supply get the circuit connections verified by the teacher.
- 5.4 Adjust the control knobs smoothly.
- 5.5 After taking the readings bring back all the control knobs to minimum position.
- 5.6 Switch off the power supply before leaving the experimental table.

6. CONCLUSION:

The spectrum of FM Signals is observed using spectrum analyzer and plotted.

7. VIVA -VOCE QUESTIONS:

- 7.1 Define a spectrum?
- 7.2 Is it possible to visualize the time domain signals using spectrum analyzer?
- 7.3 How can we select the central frequency?
- 7.4 How many side bands appear for a conventional FM signal?
- 7.5 What are the major components required to apply the FM signals to the spectrum analyzer?
- 7.6 Define a marker?
- 7.7 Draw the Spectrum of FM wave?
- 7.8 Draw the Spectrum of DSB and SSB wave?
- 7.9 What are frequencies components present in AM wave?
- 7.10 What is the need for communication?
- 7.11 Define deviation ratio and constant average power?
- 7.12 Is it possible to visualize the time domain signals using spectrum analyzer?
- 7.13 How can we select the central frequency?
- 7.14 How many side bands appear for a conventional AM signal?
- 7.15 Give the expression for sidebands power P_{SB} , P_{LSB} and P_{USB} ?
- 7.16 Write the modulation index in terms of total power and carrier power?
- 7.17 Draw the spectrum of DSB-SC?
- 7.18 Give the $S(f)$ expression for DSB-SC?
- 7.19 What are the methods used for the suppression of carrier wave from the AM wave?

- 7.20 Define Signal to noise (SNR) ratio?
- 7.21 Compare narrow and wideband FM?
- 7.22 Define Signal to noise (SNR) ratio?
- 7.23 How can we select the central frequency?
- 7.24 How many side bands appear for a conventional FM signal?
- 7.25 What are the major components required to apply the FM signals to the spectrum analyzer?
- 7.26 Define a marker?
- 7.27 Draw the Spectrum of FM wave?
- 7.28 Draw the Spectrum of DSB and SSB wave?
- 7.29 Write the figure of merit equation for DSB-SC, SSB-SC and FM?
- 7.30 What are the units of amplitude sensitivity, frequency sensitivity and phase sensitivity?

DESIGN & IMPLEMENTATION OF PRE-EMPHASIS & DE-EMPHASIS FILTERS	EXPT. NO: 6
	DATE:

1. AIM:

To design & Implementation of pre-emphasis & de-emphasis filters. Plot the corresponding waveforms from practical observations.

2. COMPONENTS & TOOLS REQUIRED:

2. 1. Resistors ... 0.75k, 1.5k
2. 2. Capacitors. ...0.1uf, 0.033uf
2. 3. Pre emphasis and de-emphasis Trainer Kit
2. 4. Cathode Ray Oscilloscope.
- 2.5. Connecting wires

3. THEORY:

In FM the interference (The noise) increases linearly with frequency, and the noise power in the receiver output is concentrated at higher frequency.

At the transmitter, weaker high frequency components of audio signal are boosted before modulation by pre-emphasis filter. At the receiver, the demodulator output passed through the De-emphasis filter, which undoes the pre-emphasis by attenuating the higher frequency components, where most of the noise is concentrated. The transfer functions of pre-emphasis and de-emphasis (PDE) are having exact opposite. Thus the process of pre-emphasis and d-emphasis leaves the desired signal untouched, but reduces the noise power considerably.

The PDE method of reduction is not limited just to FM broadcast; it is also used in audiotape recording and phonograph (analog) recording. We could also use PDE in AM broadcasting to improve the SNR, but in practice, this is not done for some reasons. That is output noise amplitude is constant with frequency, and does not vary as in FM. Hence de-emphasis does yield such a dramatic improvement in AM as it does in FM.

4. CIRCUIT DIAGRAM:

For $T = 50 \text{ usec}$

De-emphasis

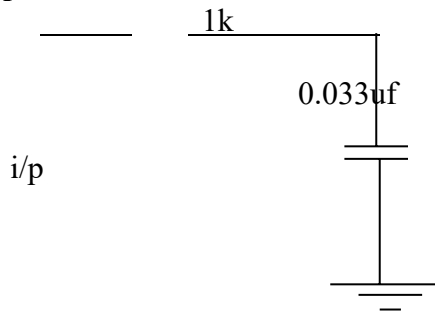

Pre-emphasis

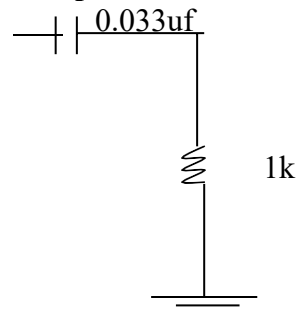

o/p

For $T = 75 \text{ usec}$:

De-emphasis

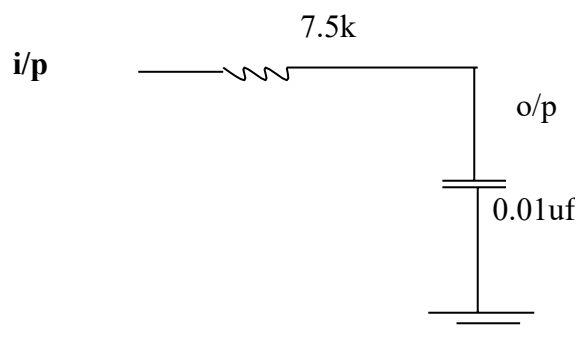

Pre-emphasis

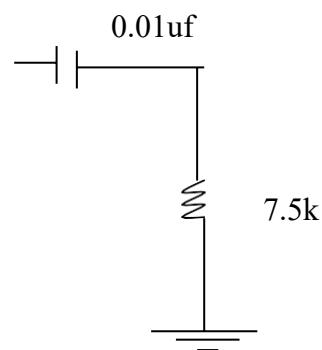

5. TABULAR COLUMNS:

Pre – emphasis

For $T = 50 \mu \text{ sec}$

Freq (Hz)	I/p Voltage	o/p Voltage

For $T = 75 \mu \text{ sec}$

Freq (Hz)	I/p Voltage	o/p Voltage

De-emphasis:

For $T = 50 \mu \text{ sec}$

Freq (Hz)	I/p Voltage	o/p Voltage

For $T = 75 \mu \text{ sec}$

Freq (Hz)	I/p Voltage	o/p Voltage

6. MODEL WAVEFORMS:

Pre-emphasis

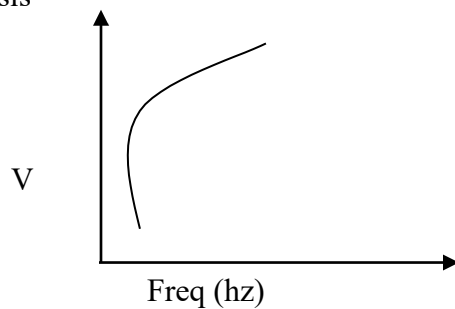

De-emphasis

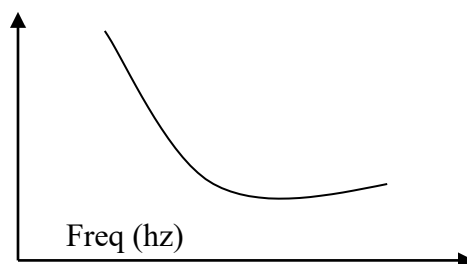

7. EXPERIMENTAL PROCEDURE:

- 7.1 Switch on the power supply through mains card.
- 7.2 As the circuitry is already wired, you just have to trace the circuit according to the circuit diagram.
- 7.3 Measure output voltage of regulated power supply (+ 12 V to – 12V).
- 7.4 Set the output of AF generator using CRO to 10 v_{pp} and frequency range 200HZ to 20KHZ
- 7.5 Connect the AF signal to one of pre-emphasis network (say 75 usec)
- 7.6 Connect one of the channel of CRO to input of the pre-emphasis network and another channel to output of pre-emphasis network and observe the both waveform simultaneously one CRO by keeping in dual mode.
- 7.7 By varying AF signal frequency (amplitude must be kept constant) in steps. Note down the corresponding input and output voltage in tabular forms.
- 7.8 Plot the graph note the frequency (X – axis) and output voltage (Y- axis).
- 7.9 From the graph note the frequency at which the output is 70.7% of input voltage and compare with the theoretical value which is given by $1/2\pi RC$.
- 7.10 Initially set the amplitude of AF generator to minimum level and sampling frequency to 1 kHz (by adjusting the preset provided in pulse generator block). Note down the output of modulator by varying amplitude of modulating signal observe the modulator output so you that you can notice the amplitude of the sampling pulses is varying in accordance with the amplitude of the modulating signal
- 7.11 Repeat all the above steps for time period 50 usec.
- 7.12 Connect AF signal to one of De-emphasis network (say 75 usec).
- 7.13 Connect one of the channel of CRO to input of the De-emphasis network and another channel to output of De-emphasis network and observe the both waveforms simultaneously one CRO by keeping in dual mode.
- 7.14 By varying AF signal frequency (amplitude must be kept constant) in steps. Note down the corresponding input and output voltages in tabular forms.
- 7.15 Plot the graph between frequency (X-axis) and output voltage (Y-axis).
- 7.16 From the graph note the frequency at which the output is 70.7% of input voltage and compare with the theoretical value which is given by $1/2\pi RC$.
- 7.17 Initially set the amplitude of AF generator to minimum level and sampling frequency to 1 kHz (by adjusting the preset provided in pulse generator block). Note down the output of modulator by varying amplitude of modulating signal observe the modulator output so you that you can notice the amplitude of the sampling pulses is varying in accordance with the amplitude of the modulating signal
- 7.18 Repeat all the above steps for time period 50 μ sec.

8. PRECAUTIONS:

- 8.1 Check for loose contacts of wires and components.
- 8.2 Keep all the control knobs in the minimum position.
- 8.3 Before switch on the power supply get the circuit connections verified by the teacher.
Adjust the control knobs smoothly.
- 8.4 After taking the readings bring back all the control knobs to minimum position.
- 8.5 Switch off the power supply before leaving the experimental table.

9. OBSERVATIONS:

9.1 For 75 μ sec Pre-emphasis network

R = K ohm,

C = μ F

Theoretical value =

Practical value =

9.2 For 50 μ sec Pre-emphasis network

R = K ohm,

C = μ F

Theoretical value =

Practical value =

9.3. For 75 μ sec De-emphasis network

R = K ohm,

C = μ F

Theoretical value =

Practical value =

9.4. For 50 μ sec De-emphasis network

R = K ohm,

C = μ F

Theoretical value =

Practical value =

SOFTWARE PROGRAM

AIM:

To generate Pre-Emphasis & De-Emphasis waves by using a MATLAB Software.

APPARATUS REQUIRED:

1. Computer
2. SCILAB/MATLAB

PROGRAM:

```
f1=10;

for f=1:50

x(f)=(1/sqrt(1+(f1/f)^2));

f2(f)=f;

end

subplot(2,1,1);

plot(f2,x);

title('pre emphasis waveform');

for f=1:50

y(f)=(1/sqrt(1+(f/f1)^2));

f3(f)=f;

end

subplot(2,1,2);

plot(f3,y);

title('de emphasis waveform');
```

Simulated Wave forms

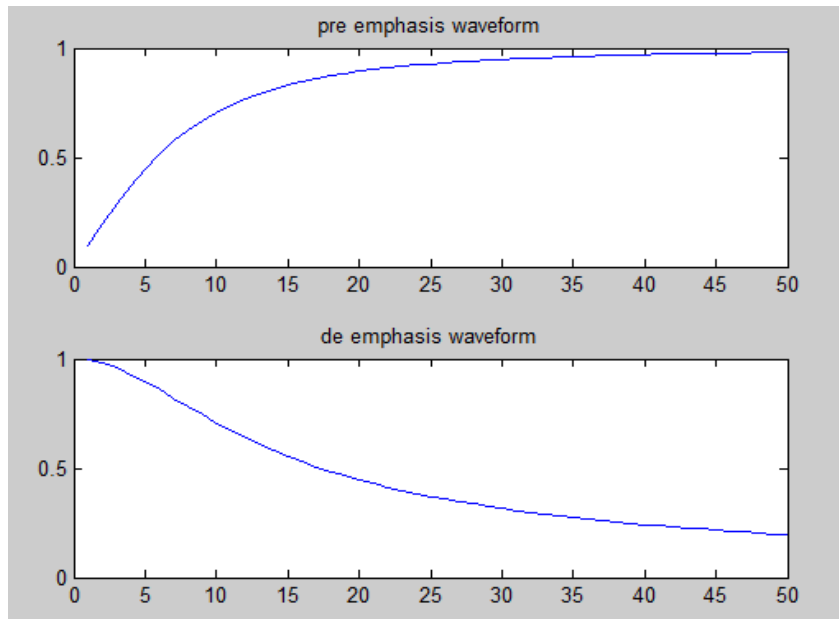

INFERENCE:

The Pre-Emphasis and De-Emphasis waves have been generated by using a MATLAB Software.

EXERCISE:

1. Generate Pre-emphasis and De-emphasis waves for $f=20$.
2. Generate Pre-emphasis and De-emphasis waves for $f=25$.
3. Generate Pre-emphasis and De-emphasis waves for $f=50$.
4. Generate Pre-emphasis and De-emphasis waves for $f=75$.
5. Generate Pre-emphasis and De-emphasis waves for $f=100$.
6. Generate Pre-emphasis and De-emphasis waves for $f=150$.
7. Generate Pre-emphasis and De-emphasis waves for $f=175$.
8. Generate Pre-emphasis and De-emphasis waves for $f=200$.
9. Generate Pre-emphasis and De-emphasis waves for $f=350$.
10. Generate Pre-emphasis and De-emphasis waves for $f=500$.
11. Generate Pre-emphasis and De-emphasis waves for $f=30$.
12. Generate Pre-emphasis and De-emphasis waves for $f=35$.
13. Generate Pre-emphasis and De-emphasis waves for $f=60$.
14. Generate Pre-emphasis and De-emphasis waves for $f=85$.
15. Generate Pre-emphasis and De-emphasis waves for $f=110$.
16. Generate Pre-emphasis and De-emphasis waves for $f=160$.
17. Generate Pre-emphasis and De-emphasis waves for $f=185$.
18. Generate Pre-emphasis and De-emphasis waves for $f=220$.
19. Generate Pre-emphasis and De-emphasis waves for $f=380$.
20. Generate Pre-emphasis and De-emphasis waves for $f=590$.
21. Generate Pre-emphasis and De-emphasis waves for $f=177$.

22. Generate Pre-emphasis and De-emphasis waves for $f=210$
23. Generate Pre-emphasis and De-emphasis waves for $f=305$.
24. Generate Pre-emphasis and De-emphasis waves for $f=550$.
25. Generate Pre-emphasis and De-emphasis waves for $f=315$.

9. CONCLUSION:

The characteristics of pre-emphasis and de-emphasis are studied and plotted.

10. APPLICATIONS:

1. Emphasis is commonly used in [LP records](#) and [FM broadcasting](#).
2. Pre-emphasis is employed in [frequency modulation](#) or [phase modulation](#) transmitters to equalize the modulating [signal](#) drive [power](#) in terms of [deviation ratio](#).
3. PLL applications to lock unwanted Noise stations.
4. Used in FMFB systems to improve modulating signal to avoid noise signals in FM systems. The receiver [demodulation](#) process includes a reciprocal network, called a de-emphasis network to restore the original sign
5. The receiver [demodulation](#) process includes a reciprocal network, called a de-emphasis network to restore the original signal power distribution.

11. VIVA -VOCE QUESTIONS:

- 11.1 What is pre-emphasis?
- 11.2 What is de-emphasis?
- 11.3 What is the necessity of pre-emphasis and de-emphasis circuits in FM?
- 11.4 Where we use the pre-emphasis and de-emphasis circuits?
- 11.5 What is the functionality of a pre-emphasis filter?
- 11.6 What is the functionality of a de-emphasis filter?
- 11.7 Define Threshold effect in FM?
- 11.8 Define Capture effect in FM?
- 11.9 Define CNR over SNR?
- 11.10 What is Figure of merit for FM?
- 11.11 What are baseband signals and what are its frequency ranges?
- 11.12 What is pre-emphasis?

- 11.13 What is de-emphasis?
- 11.14 What is the necessity of pre-emphasis and de-emphasis circuits in FM?
- 11.15 Where we use the pre-emphasis and de-emphasis circuits?
- 11.16 What is the functionality of a pre-emphasis filter?
- 11.17 What is the functionality of a de-emphasis filter?
- 11.18 Define Threshold effect in FM?
- 11.19 Define Capture effect in FM?
- 11.20 Define CNR over SNR?
- 11.21 Give the $S(f)$ expression for DSB-SC?
- 11.22 What are the methods used for the suppression of carrier wave from the AM wave?
- 11.23 Define Signal to noise (SNR) ratio?
- 11.24 Compare narrow and wideband FM?
- 11.25 Define Signal to noise (SNR) ratio?
- 11.26 How can we select the central frequency?
- 11.27 How many side bands appear for a conventional FM signal?
- 11.28 What are the major components required to apply the FM signals to the spectrum analyzer?
- 11.29 What are the basic components of communication system?
- 11.30 Draw the block diagram of electronic communication system?

TIME DIVISION MULTIPLEXING & DE-MULTIPLEXING OF ANY TWO BAND LIMITED SIGNALS

EXPT. NO: 07

DATE:

AIM:

To study the time division multiplexing by applying different band limited signals to time division multiplexer. Apply the multiplexed output to Demultiplexer and observe the individual signals.

EQUIPMENT REQUIRED: -

TDM Multiplexer and De-multiplexer kit

CRO-20/25MHz

BNC probes

Patch cards.

BLOCK DIAGRAM:

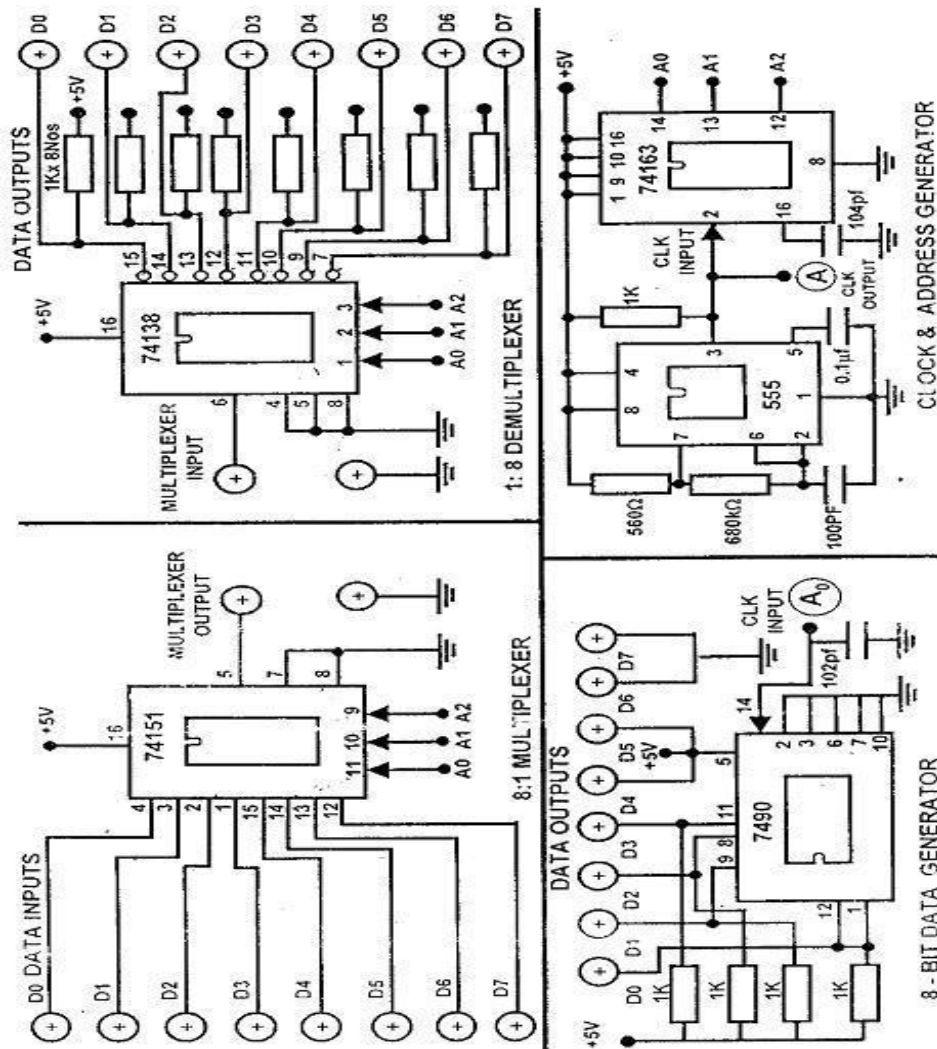

THEORY: -

A time division multiplexing system enables the joint utilization of a common communication channel by a plurality of independent message sources without mutual interference among them. Each input signal is first restricted in bandwidth by a low pass anti aliasing filter to remove the frequencies that are non-essential to an adequate signal representation. The low pass filter outputs are then applied to a commutator, which is usually implemented using electronic switching circuitry. The function of the commutator is twofold. To take a narrow sample of each of the N input messages at rate f_s that are slightly higher than $2W$ where W is the cut-off frequency of the anti-aliasing filter. To sequentially interleave these N samples inside the sampling interval T_s . In effect, this latter function is the essence of the time division multiplexing operation. Following the communication process, the multiplexed signal is applied to a pulse modulator, the purpose of which is to transform the multiplexed signal into a form suitable for transmission over the communication channel. It is clear that the use of time division multiplexing introduces a bandwidth expansion factor N because the scheme must squeeze N samples derived from N independent message sources into a time slot equal to one sampling interval. At the receiving end of the system, the received signal is applied to a pulse demodulator, which performs the reverse operation of the pulse modulator. The narrow samples produced at the pulse demodulator output are distributed to the appropriate low pass reconstruction filter by means of a demultiplexer which operates in synchronism with the commutator in the transmitter. This synchronization is essential for a satisfactory operation of the system. The way this synchronization is implemented depends naturally on the method of pulse modulation used to transmit the multiplexed sequence of samples. TDM systems are highly sensitive to dispersion in the common channel. So, accurate equalization of both magnitude and phase response of the channel is necessary to ensure a satisfactory operation of the system.

PROCEDURE:

1. Switch on Time Division Multiplexing and De Multiplexing Trainer.
2. Connect the sine wave to channel-1, square wave to channel -2 and triangle wave to channel terminals of 8 to 1 Multiplexer.
3. Observe the multiplexer output on channel -1 of a CRO.
4. Connect mux output to de-mux input.
5. Observe corresponding signal outputs at channel-2 of CRO.

MODEL GRAPH: -

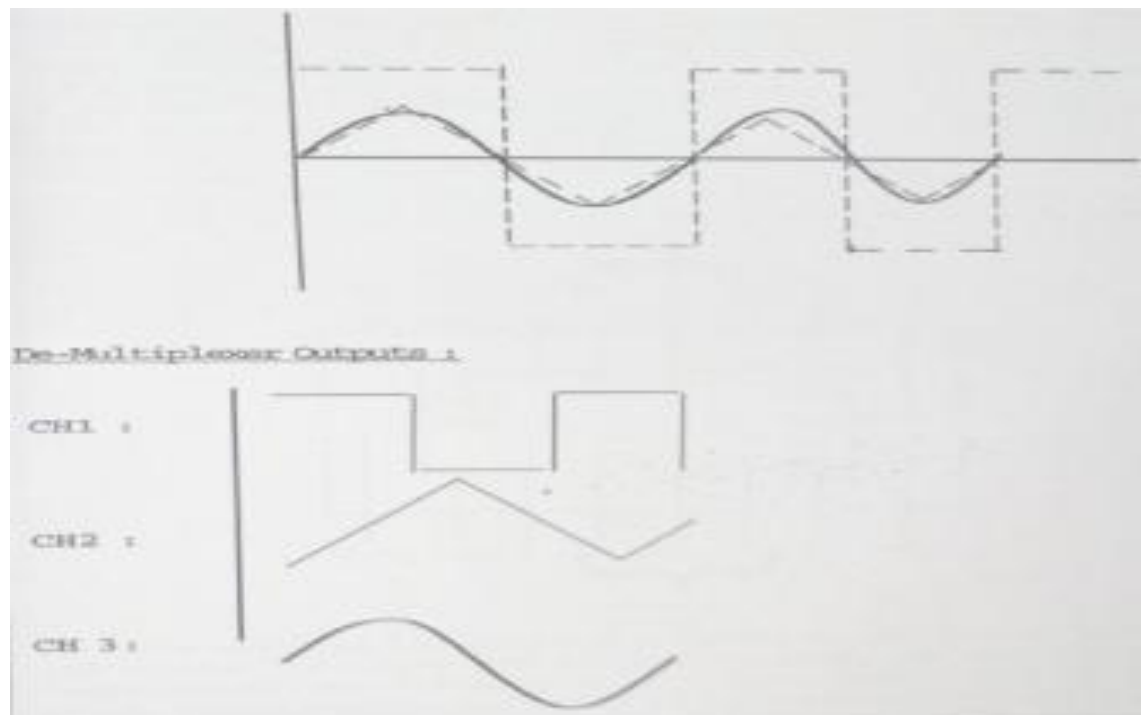

RESULT:

The operation of TDM is observed and the output waveforms are verified.

VIVA QUESTIONS:

1. What is the working principle of TDM?
2. What is the purpose of commutator in TDM?
3. In TDM how does the synchronization can be achieved?
4. What are the applications of TDM?
5. What is aperture effect?
6. What is the working principle of TDM?
7. What is the purpose of commutator in TDM?
8. In TDM how does the synchronization can be achieved?
9. What are the applications of TDM?
10. What is aperture effect?
11. Why communication is concerned with electronic equipment?
12. What are the typical channels used in wire/line communication?
13. What is multiplexing?
14. What are the types of multiplexing?
15. What are the applications of multiplexing?
16. Why we need multiplexing?
17. What are the advantages of multiplexing?
18. What is the disadvantage of multiplexing?
19. What are the advantages over modulation techniques?
20. Give the expression for modulation index (μ)?
21. Which is non orthogonal multiplexing?
22. Distinguish between the two basic multiplexing techniques?
23. Why sync pulse is required in TDM?
24. In what situation multiplexing is used?
25. What is difference between Frequency Division multiplexing and Wave Division multiplexing.
26. What is the function of an enable input on a multiplexer chip?
27. Will multiplexing create additional harmonics in the system?
28. Can I accidentally switch a dimmer to multiplex mode?
29. Why COSTAS LOOP is used?
30. What is the working principle of TDM?
31. What is the purpose of commutator in TDM?
32. Define TDM.

33. Which principle is used in TDM
34. Compare TDM with FDM
35. In which area TDM is applicable
36. Explain the generation of TDM
37. Compare PAM & TDM
38. What is the function of commentator
39. What is the function of De commentator
40. Give the application of TDM.
41. Why we need multiplexing?
42. What are the advantages of multiplexing?
43. What is the disadvantage of multiplexing?
44. What are the advantages over modulation techniques?
45. Which is non orthogonal multiplexing?
46. How to multiplex digital data
47. How could you multiplex video, audio and image at a time.
48. Distinguish between the two basic multiplexing techniques?
49. Why sync pulse is required in TDM?
50. Mention the differences between TDM and FDM.

Real Time Applications:

- In Half duplex communication system
- In Communication systems
- Wireless communication system
- Television system
- Radio Telemetry
- **Communication System** – A Multiplexer is used in communication systems, which has a transmission system and also a communication network. A Multiplexer is used to increase the efficiency of the communication system by allowing the transmission of data such as audio & video data from different channels via cables and single lines.
- **Computer Memory** – A Multiplexer is used in computer memory to keep up a vast amount of memory in the computers, and also to decrease the number of copper lines necessary to connect the memory to other parts of the computer.

VERIFICATION OF SAMPLING THEOREM

EXPT. NO: 08

DATE:

AIM:

To Verify Sampling theorem for different sampling rates, Sampling types and Duty Cycles and Plot the sampled and reconstructed Signals. Write the conclusions, based on practical observations.

EQUIPMENT REQUIRED:

Sampling theorem trainer kit.

Function generator

CRO

BNC cable

Patch cards

THEORY:

The sampling process is usually described in the time domain as such it is an operation that is basic to digital signal processing and digital communications. Though use of the sampling process an analog signal is converted into a corresponding sequence of samples that are usually spaced uniformly in time. Clearly for such a procedure to have practical utility it is necessary that we choose the sampling rate properly so that the sequence of samples uniquely defines the original signal. This is the essence of the sampling theorem.

Consider an arbitrary signal $x(t)$ of finite energy which is specified for all time. Suppose that we sample the signal $x(t)$ instantaneously and at a uniform rate, once every t_s seconds. Consequently we obtain an infinite sequence of samples spaced t_s seconds apart and denoted by $\{x(nt_s)\}$. T_s are the sampling period and its reciprocal $f_s = 1/t_s$ is the sampling rate. This ideal form of sampling is called instantaneous sampling. $X_s(t) =$

Where $X_s(t)$ is the ideal sampled signal

We may state the sampling theorem for strictly band limited signals of finite energy in two equivalent parts, which apply to the transmitter and receiver of a pulse modulation system.

Time domain statement: -

A band limited signal of finite energy and finite duration, which has no frequency components higher than f_m Hz is completely described by specifying the values of the signal at instants of time serrated by $1/2f_m$, seconds.

Frequency domain statement: -

A band-limited signal of finite energy, which has no frequency components higher than f_m Hz, may be completely recovered form, knowledge of its samples taken at the rate of $2f_m$ samples per second. The sampling rate of $2f_m$ samples per second for a signal bandwidth of f_m Hz is called the Nyquist rate and its reciprocal of $1/2f_m$ is called the Nyquist interval. This equation provides an interpolation formula for reconstructing the original signal $x(t)$ form the sequence of samples values $x(n/2f_m)$, with the sine function since $(2f_m t)$ playing the role of an interpolation function each sample is multiplied by a delayed version of the interpolation function and all resulting waveforms are added to obtain $x(t)$.

CIRCUIT DIAGRAM

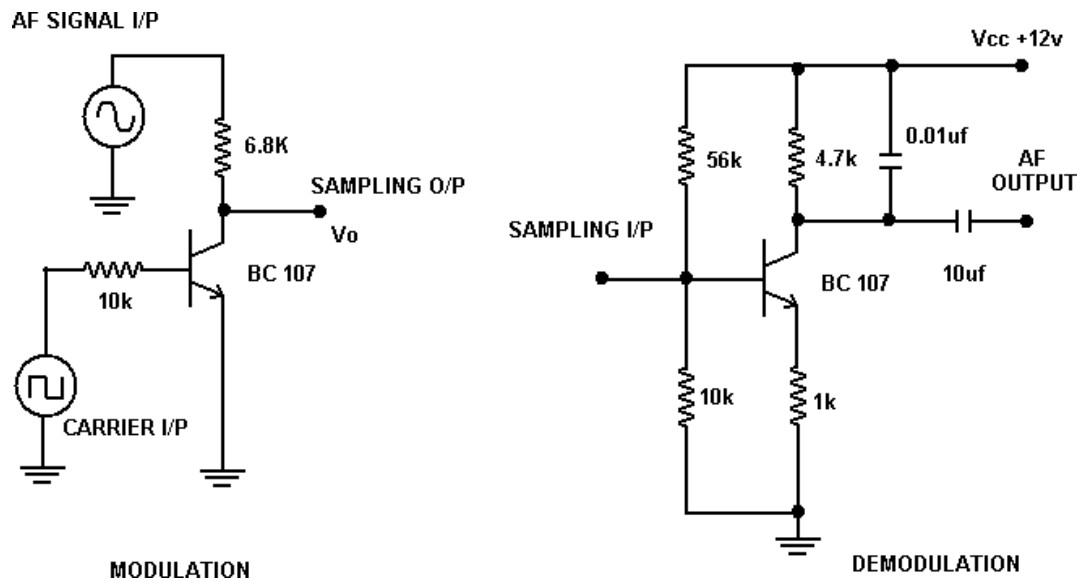

MODEL GRAPH

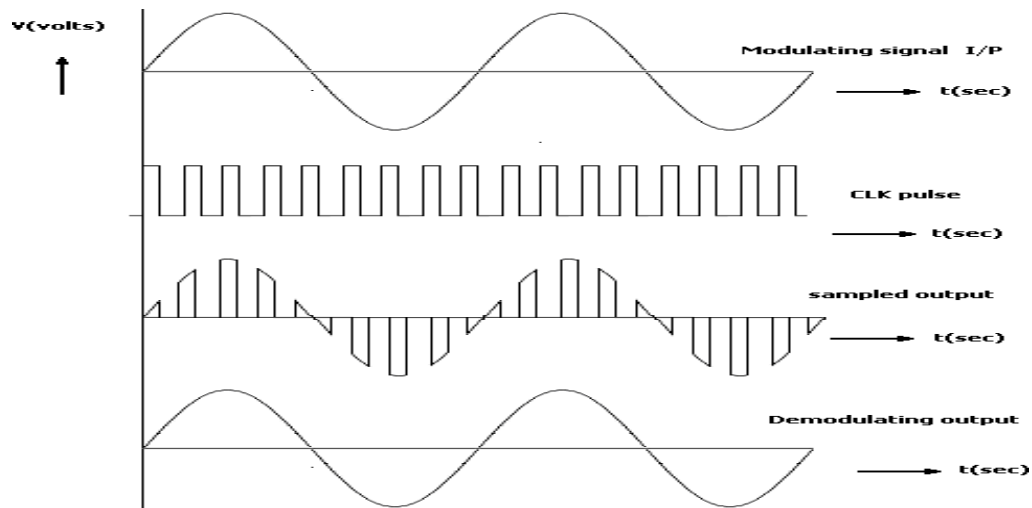

Procedure: -

1. Connect the circuit as per the circuit diagram.
2. Apply a modulating signal of frequency 1 kHz and a clock pulse of frequency 18KHz
3. Observe the sampled waveform on CRO and find the number of samples obtained.
4. Compare it with theoretical value and verify it draw the waveform of the sampled signal.

Results: - Verification of sampling theorem is done successfully for three sinusoidal signals

Applications: The sampling theorem is usually formulated for functions of a single variable. Consequently, the theorem is directly applicable to time-dependent signals and is normally formulated in that context. However, the sampling theorem can be extended in a straightforward way to functions of arbitrarily many variables.

VIVA QUESTIONS

1. Define sampling theorem.
2. What is sampling?
3. Define band limited signals?
4. What is aliasing effect?
5. How can be aliasing be avoided?

6. What is under sampling?
7. Define Nyquist rate?
8. What is sampling frequency?
9. What is modulating frequency?
10. What is sampling rate?
11. Define deviation ratio and constant average power?
12. What are the types of noise?
13. Define Signal to noise (SNR) ratio?
14. What is sampling process?
15. Give the statement of sampling theorem for band limited (low pass filtered) signals?
16. What is the Essence of Sampling theorem?
17. What is aliasing effect and how do you overcome this effect?
18. Draw the time domain waveforms for natural & flat top sampling?
19. Define Analog & Digital signals?
20. What is sampling process?

PULSE AMPLITUDE MODULATION: GENERATION AND DETECTION	EXPT. NO: 09
	DATE:

1. AIM:

To generate a Pulse Amplitude Modulated & Demodulated signals and plot the corresponding waveforms from the practical observations.

2. COMPONENTS & TOOLS REQUIRED:

- 2.1 PAM Trainer kit
- 2.2. 30 kHz dual channel oscilloscope
- 2.3. CRO probes and patch chords.

3. THEORY:

PAM is having fixed width of each pulse, but the amplitude of each pulse is made proportional to the amplitude of the modulating signal at that instant, sampling clock is applied to the base of the transistor modulating signal is applied at the collector of the transistor. So that the output of the transistor (collector current) varies according to the Modulating signal voltage. Sampling clock given at the base of the transistor will appear at the collector (same frequency of clock) but its amplitude is proportional to the modulating voltage.

The demodulation of the PAM is quite a simple process. PAM is fed to the integrating Rx circuit (LPF), from which the demodulating signal emerges whose amplitude at any instant is proportional to the PAM at that instant. This signal is given to an inverting amplifier to amplify Its level so that demodulated output is having almost equal amplitude with the modulating signal, but it is having same phase difference.

4. BLOCK DIAGRAM:

MODULATOR:

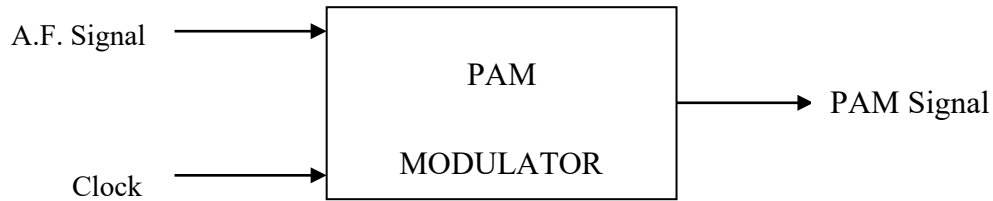

DEMODULATOR

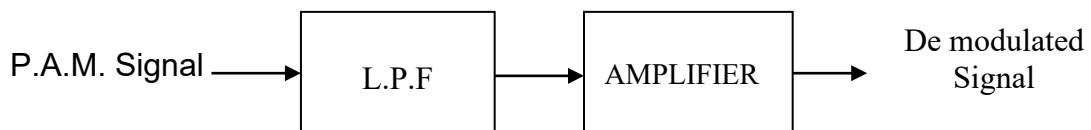

5. MODEL WAVEFORMS:

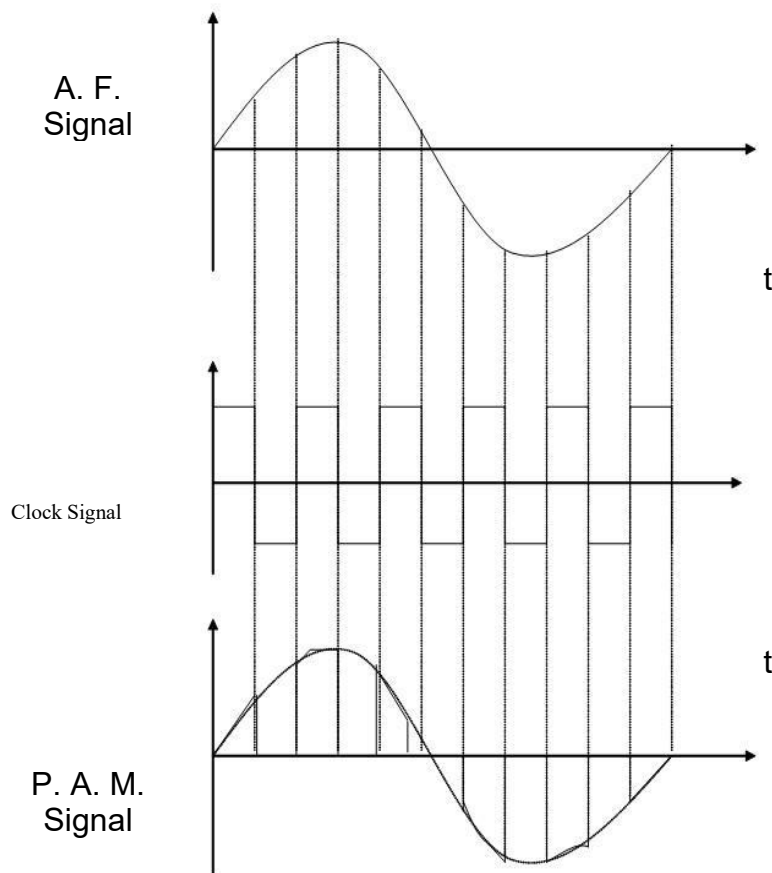

6. EXPERIMENTAL PROCEDURE:

- 6.1. Switch on the trainer kit.
- 6.2. Observe the modulating signal and carrier clock generator outputs
- 6.3. Adjust the modulating signal generator output to convenient value
- 6.4. Apply the modulating signal generator output and clock generators output to the PAM modulator.
- 6.5. Observe the PAM out put waveforms by varying the amplitudes of the modulating signal and modulation depths.
- 6.6. During demodulation connect PAM output to the input of the PAM demodulator and observe the output of PAM demodulator.

7. PRECAUTIONS:

- 7.1 Check for loose contacts of wires and components.
- 7.2 Keep all the control knobs in the minimum position.
- 7.3 Before switch on the power supply get the circuit connections verified by the teacher.
- 7.4 Adjust the control knobs smoothly.
 - 7.5 After taking the readings bring back all the control knobs to minimum position.
- 7.6 Switch off the power supply before leaving the experimental table.

8. Observations:

- 8.1. Amplitude of the modulating signal_____
- 8.2. Frequency of the modulating signal_____
- 8.3. Amplitude of the De-modulating signal_____
- 8.4. Frequency of the De-modulating signal_____
- 8.5. Sampling frequency_____

USING DISCRETE COMPONENTS

AIM :

To generate pulse amplitude modulated wave using emitter follower.

Apparatus:

S No	Component	Range	Quantity
1	Transistor	BC 107	1
2	Resistor	47kΩ,22kΩ,33kΩ	1
3	Function generator	(0-3) MHz	2
4	CRO	(0-3) MHz	1
5	RPS	(0-30)V	1

Theory:

The signal $x_s(t)$ represents a pulse amplitude modulated signal .In pulse amplitude modulation(PAM),the carrier signal consists of a periodic train of rectangular pulses, and the amplitudes of rectangular pulses vary with instantaneous sampled values of an analog message signal. Note that the carrier frequency (i.e., the pulse repetition frequency) is same as the sampling rate.

The sampling signal $x_s(t)$ can be expressed as

$$x_s(t) = \sum_{n=-\infty}^{\infty} m(nT_s) p(t - nT_s)$$

Where $p(t)$ is the rectangular pulse of unit amplitude and duration d ,

$$p(t) = \begin{cases} 1 & |t| < d/2 \\ 0 & \text{otherwise} \end{cases}$$

Procedure:

Connections are given as per the circuit diagram.

A Suitable message signal and rectangular pulse carrier wave is given as the input to the circuit.

The output is obtained at the Emitter terminal of the circuit.

The Amplitude and Frequency of the various waveforms are tabulated and verified.

Circuit diagram

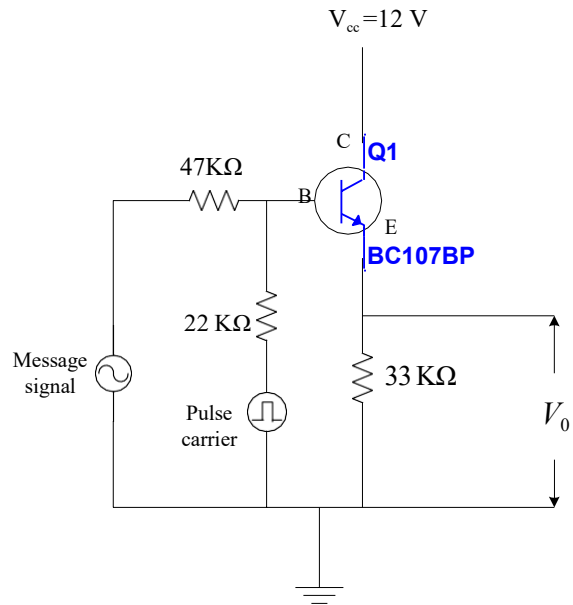

Expected graphs

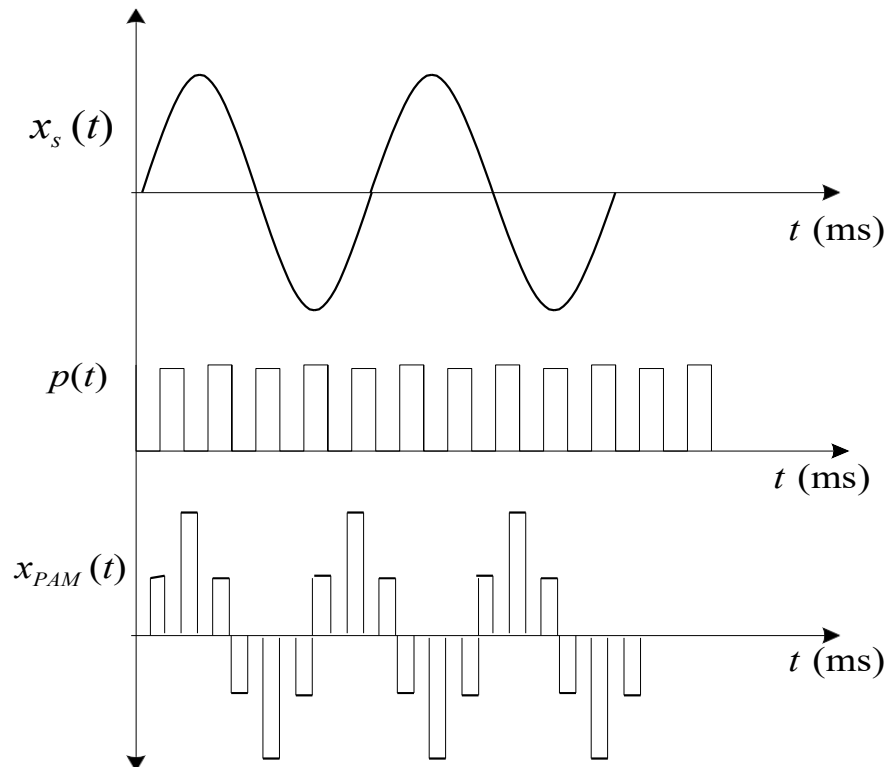

Wave form	Amplitude in Volts	Frequency in Hertz
Message $[x_s(t)]$		
Pulse carrier signal $[p(t)]$		
Pulse amplitude modulated signal $[x_{PAM}(t)]$		

Result:

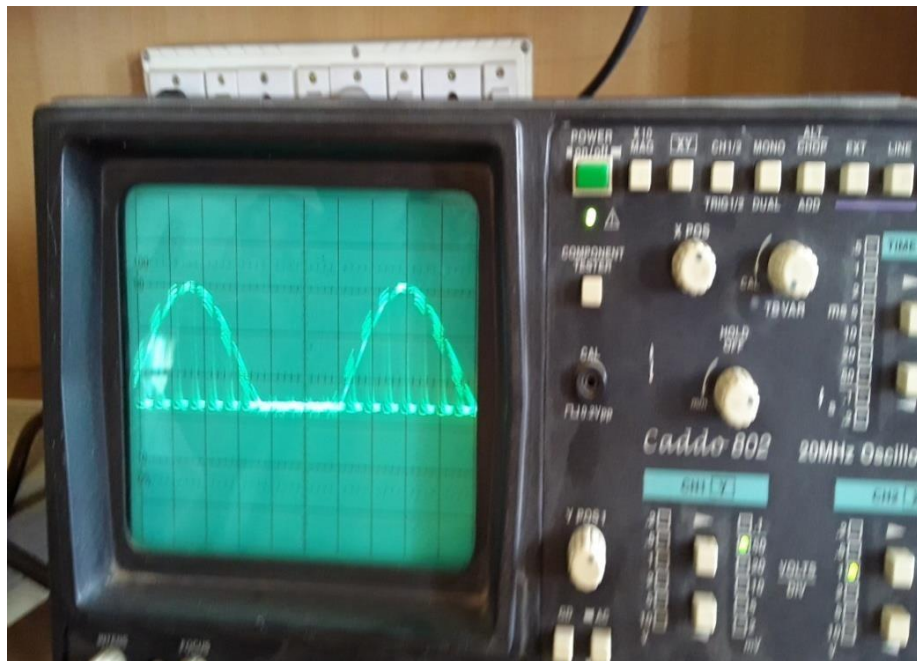
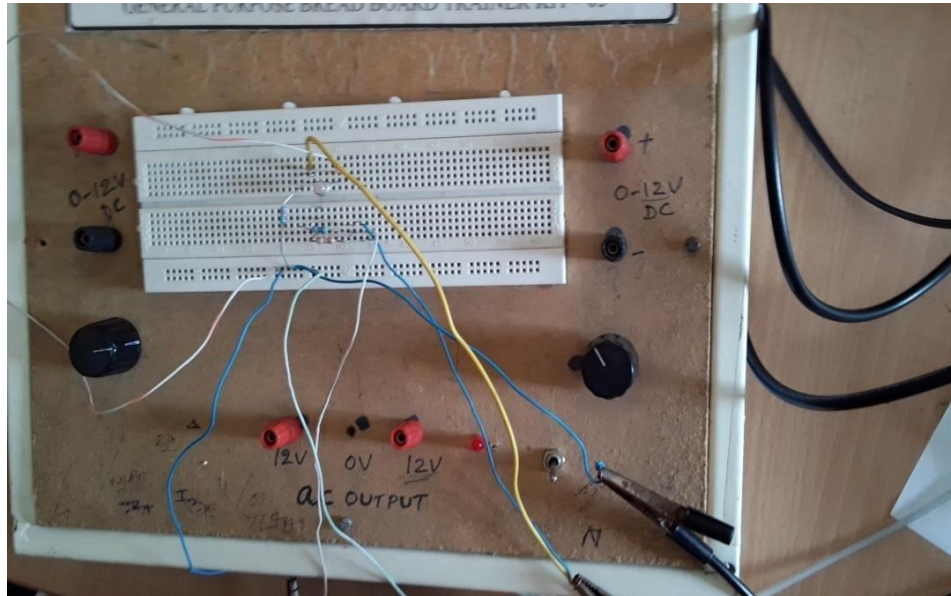

Thus, the pulse amplitude modulated wave is obtained using components.

SOFTWARE PROGRAM

AIM:

To generate and detect PAM wave by using a SCILAB/MATLAB software.

APPARATUS REQUIRED:

1. Computer
2. SCILAB/MATLAB SOFTWARE

PROGRAM:

```
clc;
clf;
close all
clear all
t=0:1/6000:((10/1000)-(1/6000));
xa=sin(2*pi*100*abs(t));
Ts=32;
x=sin(2*pi*600*(Ts*t));
X=fft(xa,abs(x));
subplot(3,1,1)
plot(xa);
grid
subplot(3,1,2);
stem(X);
grid
Y=ifft(xa,X);
subplot(3,1,3)
plot(Y)
grid
```

Simulated Wave forms:

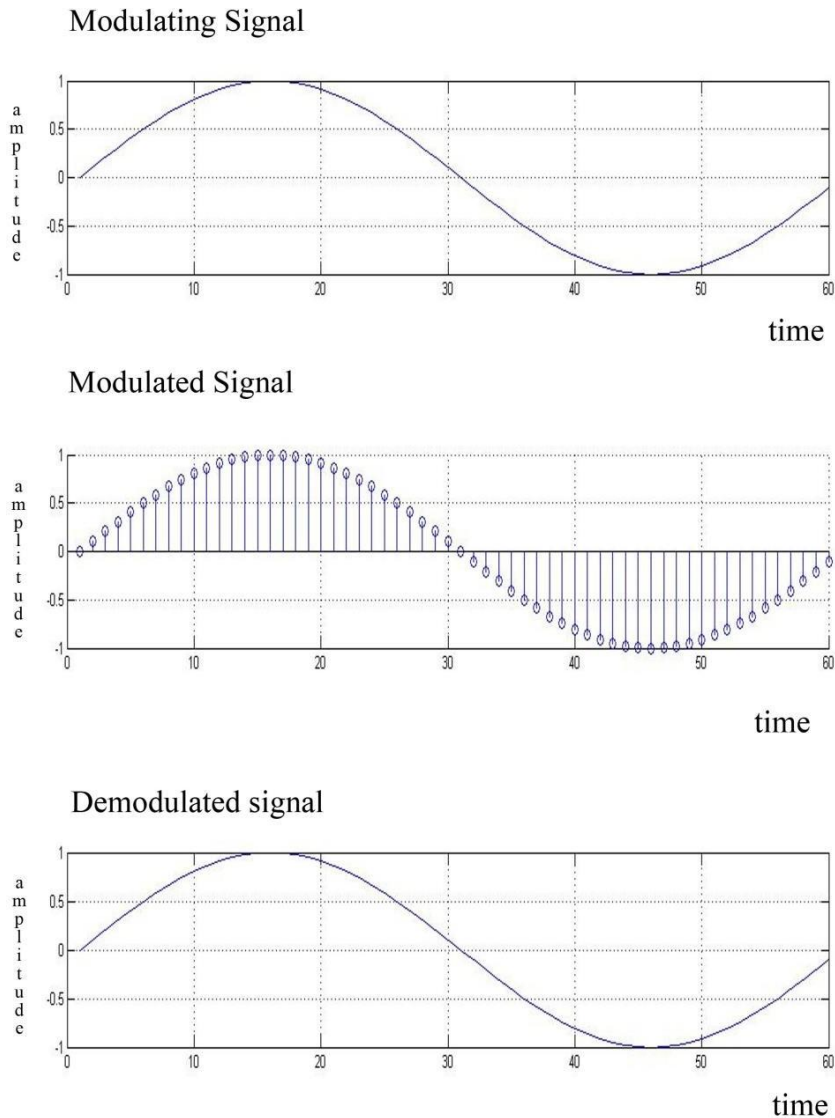

INFERENCE:

The PAM wave has been generated and detected by using MATLAB software.

EXERCISE:

- 1) Generate a PAM wave with message frequency 200hz and carrier frequency 2000Hz.
- 2) Detect a PAM wave with message frequency 200hz and carrier frequency 2000Hz.
- 3) Generate a PAM wave with message frequency 50hz and carrier frequency 1000Hz.
- 4) Detect a PAM wave with message frequency 50hz and carrier frequency 1000Hz.
- 5) Generate a PAM wave with message frequency 500hz and carrier frequency 10000Hz.
- 6) Detect a PAM wave with message frequency 500hz and carrier frequency 10000Hz.
- 7) Generate a PAM wave with message frequency 300hz and carrier frequency 2000Hz.
- 8) Detect a PAM wave with message frequency 300hz and carrier frequency 2000Hz.
- 9) Generate a PAM wave with message frequency 300hz and carrier frequency 5000Hz.
- 10) Generate a PAM wave with message frequency 300hz and carrier frequency 5000Hz.

- 11) Generate a PAM wave with message frequency 250hz and carrier frequency 2500Hz.
- 12) Detect a PAM wave with message frequency 250hz and carrier frequency 2500Hz.
- 13) Generate a PAM wave with message frequency 150hz and carrier frequency 1500Hz.
- 14) Detect a PAM wave with message frequency 150hz and carrier frequency 1500Hz.
- 15) Generate a PAM wave with message frequency 550hz and carrier frequency 10500Hz.
- 16) Detect a PAM wave with message frequency 550hz and carrier frequency 10500Hz.
- 17) Generate a PAM wave with message frequency 350hz and carrier frequency 2500Hz.
- 18) Detect a PAM wave with message frequency 350hz and carrier frequency 2500Hz.
- 19) Generate a PAM wave with message frequency 380hz and carrier frequency 6000Hz.
- 20) Generate a PAM wave with message frequency 380hz and carrier frequency 6000Hz.
- 21) Detect a PAM wave with message frequency 100hz and carrier frequency 50000Hz.
- 22) Generate a PAM wave with message frequency 200hz and carrier frequency 1000Hz.
- 23) Detect a PAM wave with message frequency 150hz and carrier frequency 2000Hz.
- 24) Generate a PAM wave with message frequency 500hz and carrier frequency 2500Hz.
- 25) Generate a PAM wave with message frequency 200hz and carrier frequency 3000Hz.

9. CONCLUSION:

The pulse amplitude modulation and demodulation is studied, verified and the output waveforms are plotted.

10. VIVA -VOCE QUESTIONS:

1. What is sampling?
2. What is sampling theorem?
3. What are the various types of Pulse modulation techniques?
4. Define PAM?
5. What is the use of pulse shaping network?
6. What is the purpose of sample and hold circuit?
7. What is Bandwidth required for PAM signal?
8. What is Nyquist Criteria?
9. Draw the block diagram for the detection of PAM signal.
10. What are the advantages and drawbacks of PAM.
11. Give expression for the FM wave as well as PM wave?
12. Compare narrow and wideband FM?
13. What are the merits & demerits of PAM?
14. Draw the time domain waveforms for natural & flat top sampling?
15. Draw the block diagram to generate PAM with schematic?
16. Draw the waveforms for the single polarity PAM and double polarity PAM?
17. How do you demodulate PAM signal?

18. What are the merits & demerits of PAM?
19. What are the advantages of PWM over PAM?
20. What are the advantages of PPM over PWM (or) PAM?
21. What is the need for communication?
22. What are the analog analogies of PAM, PPM, and PWM?
23. Explain briefly how PAM can vary in different systems?
24. What is PAM in practical circuits?
25. What is the basic principle of PAM?
26. What does "roll off" mean?
27. What are passive filters?
28. What is band pass filter?
29. What is an ideal band pass filter?
30. What is a precision rectifier?

11. REAL-TIME APPLICATIONS:

1. Some versions of the Ethernet communication standard are an example of PAM usage.
2. The concept is also used for the study of photosynthesis using a specialized instrument that involves a spectro-fluorometric measurement of the kinetics of fluorescence rise and decay in the light-harvesting antenna of thylakoid membranes.
3. Querying various aspects of the state of the photo systems under different environmental conditions.
4. Used in discrete time systems.
5. Analog to Digital Converters.

PULSE CODE MODULATION: GENERATION AND DETECTION

EXPT. NO: 10

DATE:

AIM:

To generate PCM Modulated Signal and demodulate it by designing and implementing the corresponding Demodulator. Plot the corresponding waveforms from practical observations

EQUIPMENT REQUIRED:

1. Pulse code modulation and demodulation trainer kit
2. Dual trace oscilloscope –20M Hz
3. BNC probes
4. Patch cards

BLOCK DIAGRAM:

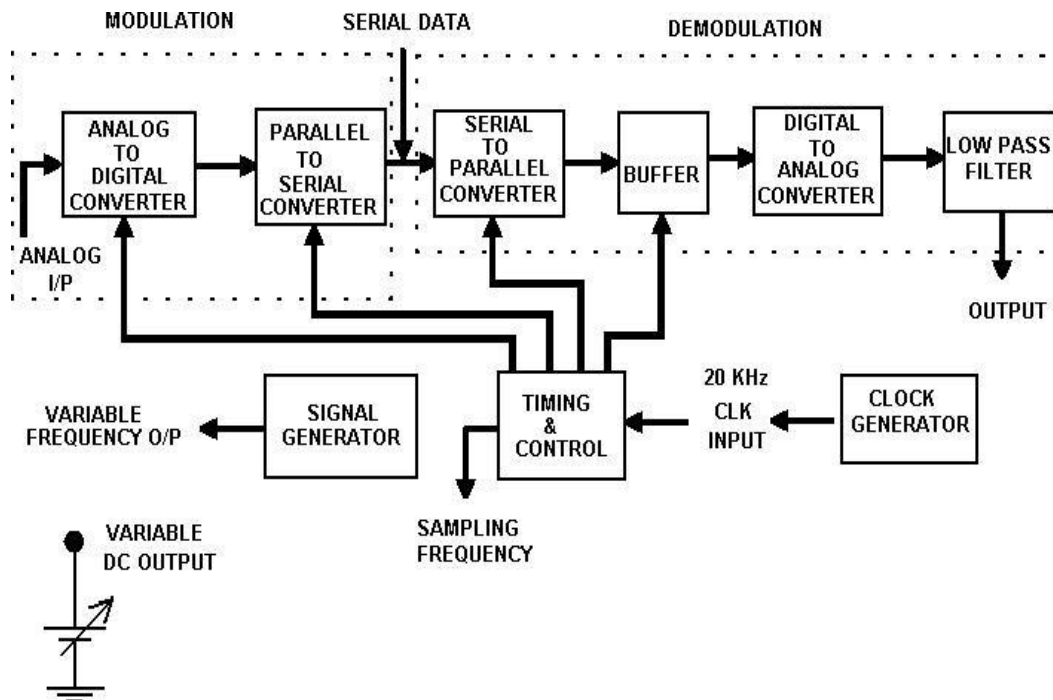

THEORY:

PCM also uses the sampling technique but it differs from the others in that it is a digital process. That is instead of sending a pulse train capable of continuously varying one of the parameters the PCM generator produced a series of numbers of digits each one of these digits almost always in binary code represents the approximate amplitude of the signal sample at that instant.

In PCM the total amplitude range which the signal may occupy is divided into number of standard levels, the actual number of levels is power 2 by a process called quartering the level actually sent at any sampling time is the nearest standard level. the digit 7 is sent at the instant of time as a series of pulses corresponding to number 7 since there are 16 levels 4 binary places are required the number becomes 0111 and could be sent as OPPP where P= pulse and O no. of pulses. Actually it is often sent as a binary back to front i.e. as 1110 or PPP0 to make demodulation easier.

The signal is continuously sampled quantized coded and sent as each sample amplitude is connected to the nearest standard amplitude and into the corresponding back to front binary number provide soggiest quartering levels are used, the result cannot be distinguished from that of analog transmission. A signaling bit is generally added to each code group representing a quantized sample. Hence each group of pulsed denoting a sample here called a word is expressed by means of $n+1$ -bit whiter 2^n is the chosen number of standard levels.

PCM requires very complex encoding quartering circuitry. PCM requires a large bandwidth compared to analog systems the main application of PCM is telegraphy the use of PCM is broadband network of advanced countries is increasing by leaps and bounders PCM also finds use in space communications.

PROCEDURE:

1. Connect the circuit as shown in figure.
2. Apply varying digital input.
3. Calculate decimal number form the applied binary and it will be obtained by observing LED's.
4. The demodulated output voltage is calculated theoretically by using the formul
$$v = 5 - (\text{Decimal} * 5/128).$$
5. Observe the demodulated output voltage in Multi-meter.

TABULAR FORM:

S.NO.	Applied DC voltage	Binary input	Practical value

MODEL GRAPH:

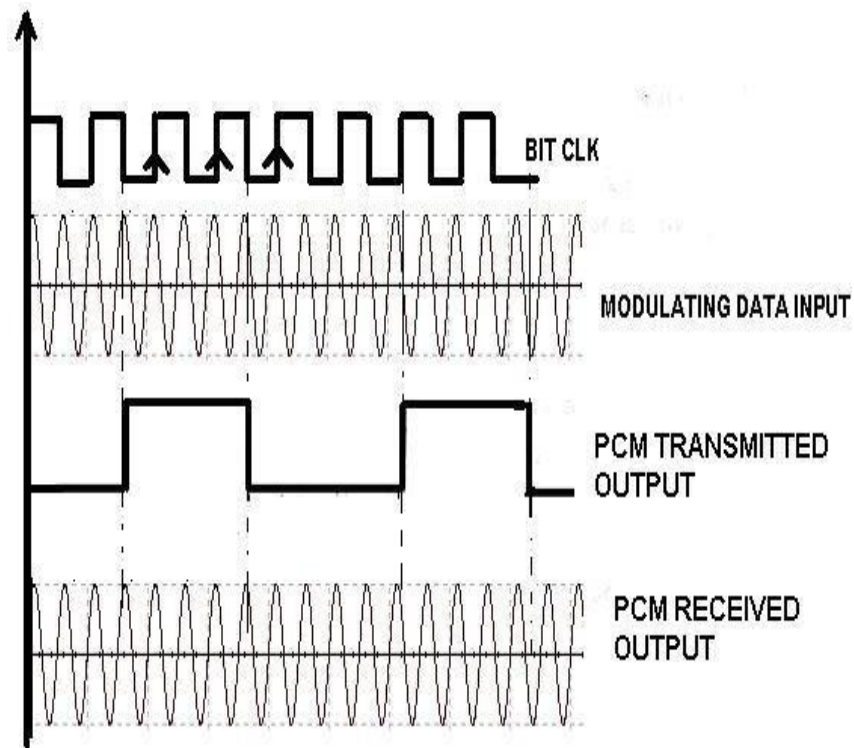

RESULT: Thus, the A/D and D/A are converted using PCM modulation and demodulationsystems

VIVA QUESTIONS:

1. What is the expression for transmission bandwidth in a PCM system?
2. What is the expression for signalling rate in a PCM system?
3. Explain Sampling Theorem for band limited signals.
4. Draw the internal structure of PCM encoder.
5. Define quantization in PCM.
6. How an ADC works in PCM.
7. What are the components of ADC?
8. Why ADC requires Parallel to series converter.
9. What is band pass sampling?
10. What is the expression for quantization noise /error in PCM system?
11. What are the applications of PCM?
12. Define encoding in PCM.
13. Why buffer is placed in PCM generation.

14. Compare PCM and DPCM.
15. What are the advantages of the PCM?
16. What are the disadvantages of PCM?
17. Essence of Sampling in PCM.
18. Write is the expression for Nyquist rate and Nyquist interval?
19. Define the term quantization noise.
20. What is quantizing error?
21. Construct the generation block diagram of pulse code modulation.
22. What is a word in PCM mean?
23. What is mean by quantization?
24. What is the major effect in PCM?
25. What happens to amplitude in PCM?
26. How to reconstruct a PCM data.
27. Define Sampling in PCM.
28. Draw the detection block diagram of pulse code modulation.
29. How a Sample and Hold (S/H) will provide Stair case waveform.
30. How a DAC works in PCM.
31. What are the components of DAC?
32. Why DAC requires series to Parallel converter.
33. What are the types of sampling?
34. Write the statement of Sampling Theorem.
35. What is base band sampling?
36. Why buffer is placed in PCM detection.
37. What are the amplitude levels of a binary PCM?
38. Why q-level quantizer is used in PCM.
39. What is relation between quantization levels and no of binary digits?
40. What is the step size in PCM?
41. Difference between PCM and DM.
42. Why step size is fixed in PCM.
43. Why PCM will have redundant samples.
44. What are the encoding methods in PCM?
45. Where we use PCM encoders.

46. If PCM data contains duplicate samples then what we need to do.
47. Draw the internal structure of PCM decoder.
48. What is the transmission bandwidth of PCM?
49. How PCM signals are used in CODEC systems.
50. Why PCM requires high data rates.

Real Time Applications:

- CD laser Discs
- Voice mail
- Digital Telephony
- Compact Disc Audio and Video recording
- Space Communication
- Magnetic tape recoding
- Radio Transmission
- TV broadcasting
- Digital audio processing in computers

DIFFERENTIAL PULSE CODE MODULATION: GENERATION AND DETECTION

EXPT. NO : 11

DATE:

AIM:

To generation and detection differential pulse code modulation and plot the corresponding waveforms from practical observations.

EQUIPMENT REQUIRED:

1. Differential Pulse code modulation and demodulation trainer kit
2. Dual trace oscilloscope –20M Hz
3. BNC probes
4. Patch cards

BLOCK DIAGRAM:

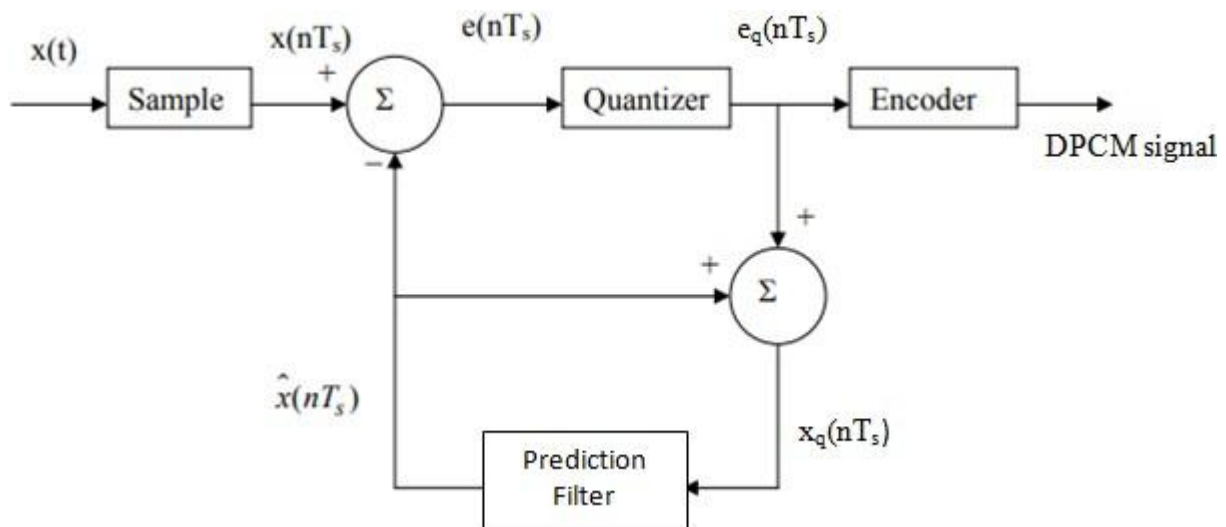

THEORY:

PCM also uses the sampling technique but it differs from the others in that it is a digital process. That is instead of sending a pulse train capable of continuously varying one of the parameters the PCM generator produced a series of numbers of digits each one of these digits almost always in binary code represents the approximate amplitude of the signal sample at that instant.

The signal is continuously sampled quantized coded and sent as each sample amplitude is connected to the nearest standard amplitude and into the corresponding back to front binary number provide soggiest quartering levels are used, the result cannot be distinguished from that of analog transmission.

A signaling bit is generally added to each code group representing a quantized sample. Hence each group of pulsed denoting a sample here called a word is expressed by means of $n+1$ -bit whiter 2^n is the chosen number of standard levels. PCM requires very complex encoding quartering circuitry. PCM requires a large bandwidth compared to analog systems the main application of PCM is telegraphy the use of PCM is broadband network of advanced countries is increasing by leaps and bounders PCM also finds use in space communications.

PROCEDURE:

1. Switch 'ON' the experimental kit.
2. Apply the variable D.C. signal to the input terminals of DPCM.
3. Observe the sampling output on CRO.
4. Observe the output of DPCM on the second channel of CRO.
5. By adjusting the D.C. Voltage potentiometer, we can get the DPCM output from 0000 0000 to 1111 1111.
6. Now, disconnect the D.C. voltage and apply AF oscillator output to the input of the DPCM Modulator.
7. Observe the output of conditioning amplifier (Differential output) and DPCM outputs in synchronization with the sampling signal.
8. During demodulation, connect DPCM output to the input of the Demodulation and observe the output of DPCM Demodulations.

MODEL GRAPH:

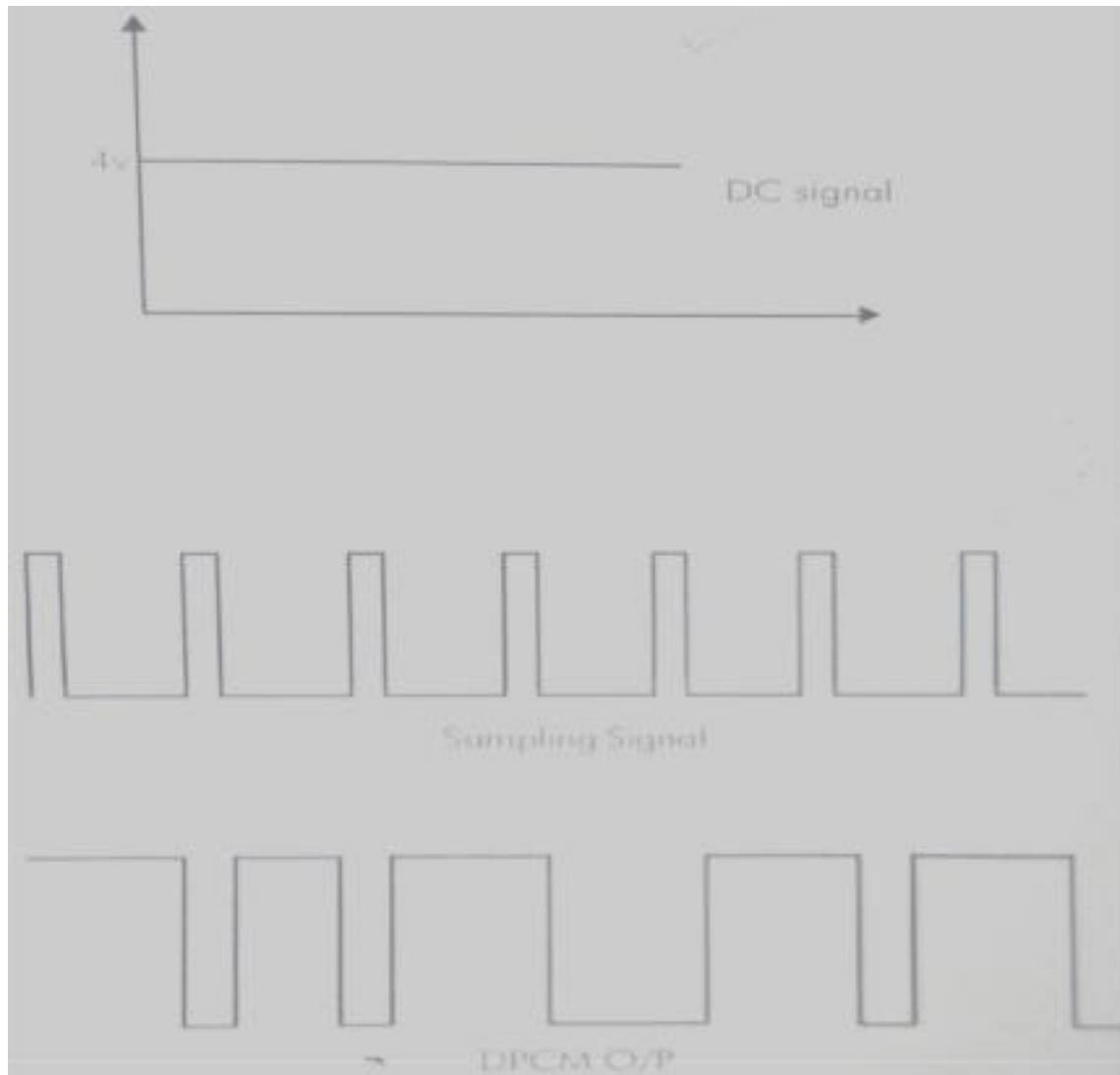

RESULT: Hence observed differential pulse code modulation and demodulation

VIVA QUESTIONS:

1. Define Differential PCM.
2. How DPCM is generated.
3. What is the drawback of PCM?
4. Compare DPCM with delta modulation.
5. How prediction filter is used to generate next samples in DPCM.
6. DPCM is which type of modulation.

7. What are the drawbacks of PCM?
8. Draw the internal structure of PCM encoder.
9. Define quantization in PCM.
10. How an ADC works in PCM.
11. What are the components of ADC?
12. Why ADC requires Parallel to series converter.
13. What is band pass sampling?
14. What is the expression for quantization noise /error in PCM system?
15. What are the applications of PCM?
16. Define encoding in PCM.
17. Why buffer is placed in PCM generation.
18. Compare PCM and DPCM.
19. What are the advantages of the PCM?
20. What are the disadvantages of PCM?
21. Essence of Sampling in PCM.
22. Write is the expression for Nyquist rate and Nyquist interval?
23. Define the term quantization noise.
24. What is quantizing noise?
25. Construct the generation block diagram of pulse code modulation.
26. What is encoding quartering circuitry?
27. What is a word in PCM mean?
28. What is mean by quantization?
29. What is the major effect in PCM?
30. What happens to amplitude in PCM?
31. How to reconstruct a PCM data.
32. Define Sampling in PCM.
33. Draw the detection block diagram of pulse code modulation.
34. How a Sample and Hold (S/H) will provide Stair case waveform.
35. How a DAC works in PCM.
36. What are the components of DAC?
37. Why DAC requires series to Parallel converter.
38. What are the types of sampling?
39. Write the statement of Sampling Theorem.
40. What is base band sampling?

41. Why buffer is placed in PCM detection.
42. What are the amplitude levels of a binary PCM?
43. Why q-level quantizer is used in PCM.
44. What is relation between quantization levels and no of binary digits?
45. What is the step size in PCM?
46. Difference between PCM and DM.
47. Why step size is fixed in PCM.
48. Why PCM will have redundant samples.
49. What are the encoding methods in PCM?
50. If PCM data contains duplicate samples then what we need to do.

Real Time Applications:

- It is used in lossy compression techniques.
- Coarser Quantization.
- Audio compression method.
- Correlation techniques.
- Compression of mpeg□
- Voice mail

- Digital Telephony
- Compact Disc Audio and Video recording
- Space Communication
- Magnetic tape recording

AIM:

To generate Delta Modulated Signal and demodulate it by designing and implementing the corresponding Demodulator. Plot the corresponding waveforms from practical observations.

EQUIPMENT REQUIRED:

- Delta Modulation and Demodulation Trainer kit.
- CRO- 20/25MHz
- BNC probes
- Patch cards.

BLOCK DIAGRAM:

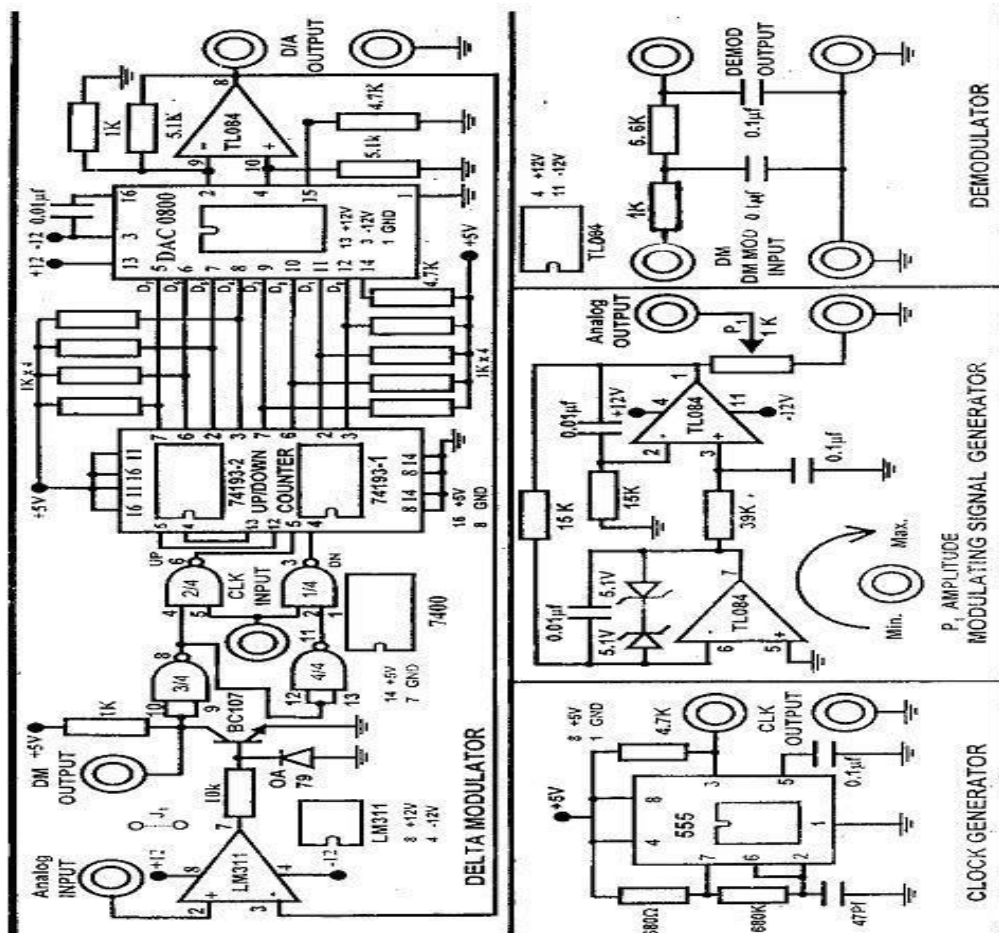

THEORY:

Delta modulation may be viewed, as a simplified form of DPCM in which two level quantizers are used in conjunction with a fixed first order predictor. DPCM is based on the exploitation of signal correlation when base band signals are sampled at Nyquist rate correlation between the adjacent samples can be further increased by over sampling the signal at a rate much higher than the Nyquist rate. The higher correlation between the samples permit. Method to use a simpler quantizing strategy for constructing the encoded signal. The very concept has led to the development of delta modulation is a one bit variation of DPCM. Applying the sampled version of the incoming message signal to a modulator that involves a summer, quantiser and an accumulator interconnected can generate delta modulation. The key to effective use of delta modulation is the proper choice of the step sizes and the sampling rate. The parameters must be chosen in such a way that staircase signal is close approximation of actual analog waveform. Since the signal has given fixed upper frequency, we know that the fastest rate at which it can change however to account for the fastest possible in the signal the step size or sampling frequency must be increased increasing the sampling frequency results in the delta modulated waveforms that require a large bandwidth increasing the step size increases the quantising error.

PROCEDURE:

1. Switch ON the experimental board.
2. Connect Clock Signal to the Delta Modulator circuit.
3. Connect Modulating Signal to the Modulating signal input of the Delta Modulator and observe the same on channel I of a Dual Trace Oscilloscope.
4. Observe the Delta Modulator output on channel II of CRO.
5. Connect this Delta Modulator output to the demodulator. Also connect the clock signal to the demodulator.
6. Observe the Demodulator output with and without RC filter on CRO.

MODEL GRAPHS:

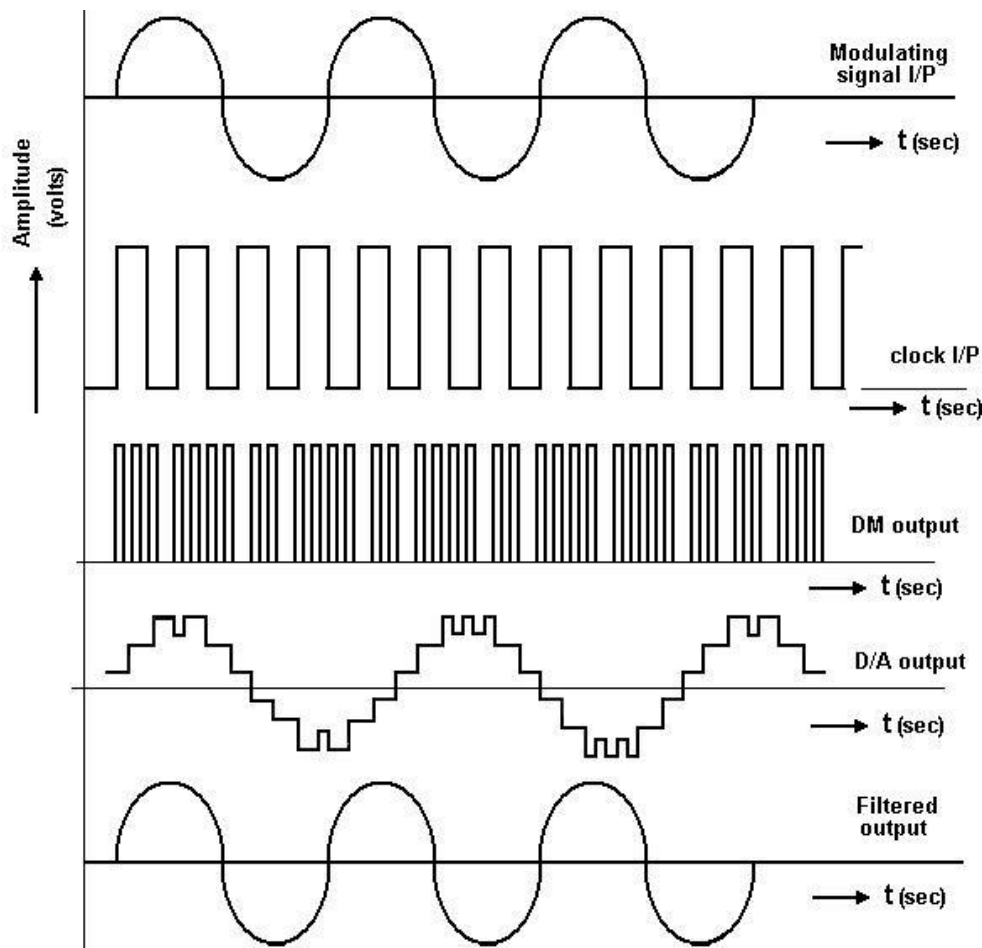

RESULT: Hence studied and observed delta modulation and demodulation

VIVA QUESTIONS:

1. Define Delta Modulation.
2. Explain the generation process of DM
3. What are the drawbacks of DM?
4. Compare DM with ADM.
5. What is meant by slope over load distortion?
6. What is the advantage of DM compare with DPCM?
7. Why Delta modulator requires low bit rates.

8. What is meant by granular noise distortion?
9. Define one bit quantization in DM.
10. How an ADC works in PCM and DM.
11. What are the components of DM?
12. What is band pass sampling?
13. What is the expression for quantization noise /error in DM system?
14. What are the applications of Delta Modulation?
15. Define accumulator in PCM.
16. Why delay unit is placed in DM generation.
17. Compare DM and DPCM.
18. What are the advantages of the DM over PCM?
19. What are the disadvantages of DM over PCM?
20. Essence of Sampling in DM.
21. Write is the expression for Nyquist rate and Nyquist interval?
22. Define the term quantization noise.
23. What is quantizing error?
24. Construct the generation block diagram of delta modulation.
25. What is encoding quartering circuitry?
26. What is a word in DM means?
27. What is mean by 1-bit quantization?
28. What is the major effect in PCM on DM?
29. What happens to amplitude levels in DM?
30. How to reconstruct a DM signal.
31. Define Sampling.
32. Draw the detection block diagram of Delta modulation.
33. How a Sample and Hold (S/H) will provide Stair case waveform.
34. How a DAC works in DM.
35. What are the components of DAC?
36. What are the types of sampling?
37. Write the statement of Sampling Theorem.
38. What is base band sampling?
39. How to compensate Granular in DM.
40. Why buffer is placed in DM detection.
41. What are the amplitude levels of a DM?

42. Why 1-bit quantizer is used in DM.
43. What is relation between quantization levels and no of binary digits?
44. What is the step size in DM?
45. Difference between DM and ADM.
46. Why step size is fixed in DM.
47. How to compensate Slope over load distortion in DM.
48. Why step size must be varied in ADM than DM.
49. How delay unit is used to generate predicted values in DM.
50. How to reconstruct a DM signal.

Real Time Applications:

- DM is used in Television systems
- PWM signals.
- Conversion of A to D signals
- In high pass filters
- To reduce the noise

AMPLITUDE SHIFT KEYING: GENERATION AND DETECTION

EXPT. NO: 13

DATE:

AIM:

To observe the variation in amplitude of carrier signal corresponding to applied binary sequence.

EQUIPMENT REQUIRED:

ASK Modulation & demodulation trainer kit

Function generator

CRO

BNC cable

Patch cards

BLOCK DIAGRAM:

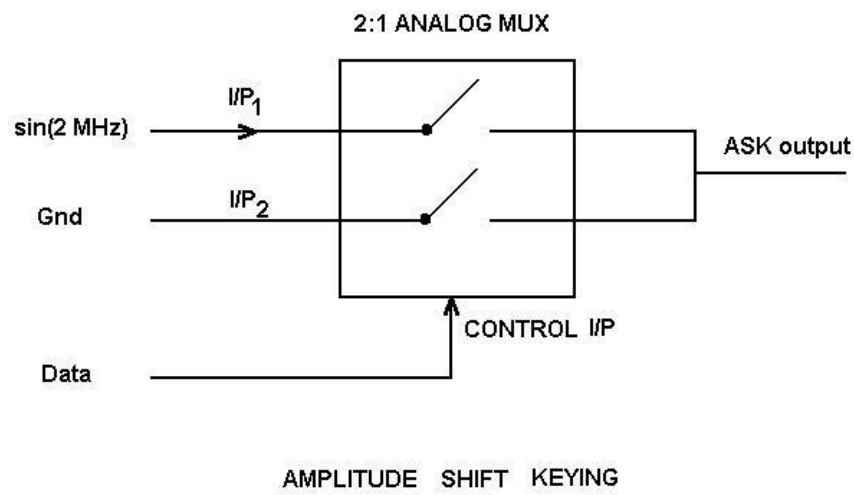

THEORY:

The binary ASK system was one of the earliest forms of digital modulation used in wireless telegraphy. In a system transmitting a sinusoidal carrier wave of fixed amplitude A_c and fixed frequency F_c represents binary symbol. For the bit duration T_b are when an binary symbol is represented by switching off the carrier for T_b . The signal can be generated by simply Turing the carriers of sinusoidal oscillation ON-OFF for the prescribed periods indicated by modulating pulse train.

Generations of ask: -

ASK applying the incoming binary data and the sinusoidal carrier to the inputs of 2:1 multiplexer and control input as reflect signal can generate signal. The ASK signal which is basically the product of binary data and sinusoidal data has PSO name as that of base band ON-OFF signal but is shifted in frequency domain by $\pm F_c$. The ASK output has an infinity bandwidth but practically the bandwidth is equal to that of an ideal and band pass filter is approximately $3/T_b$ Hz.

Demodulation of ASK: -

The demodulation of ASK wave can be done with the help of envelope detector / coherent detector. This detection involves the use of linear operation here the local carrier is assumed to be in perfect synchronization with the modulating signal.

PROCEDURE:

1. Circuit connected as shown in the figure.
2. Apply the binary data to the input and give NRZ-M to control input of modulator circuit.
3. Apply sine wave to second input of the modulator.
4. Observe the output waveform on the modulator.
5. Now give the modulated output to demodulator or input and check whether the binary data is corrected or not.

MODEL GRAPHS:

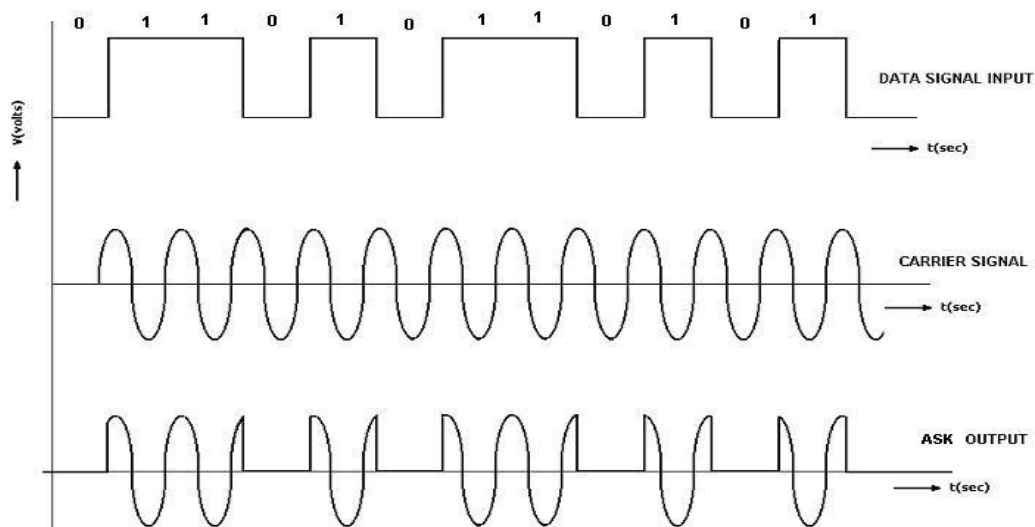

RESULTS: Hence generated Amplitude modulated and demodulated signals.

VIVA QUESTIONS:

1. Define ASK?
2. Explain the generation proven of ASK?
3. Differentiate ASK & AM?
4. Give the application of ASK?
5. ASK is which type of modulation?
6. Compare ASK & FSK?
7. Give the advantages ASK?
8. State different types of Digital modulation techniques?
9. What is shift keying?
10. What is a binary modulation technique?
11. What are applications of shift keying?
12. State coherent detection?
13. State non/coherent detection?
14. Define Baseband and Pass band digital transmission.
15. What are the requirements of Digital Modulation Techniques?
16. What are the advantages of Digital Modulation Techniques?
17. What are the disadvantages of Digital Modulation Techniques?
18. Define ASK, FSK and PSK?
19. What are the types of Digital Modulation Techniques ? Explain
20. State various continuous wave (CW) modulation systems .
21. Represent ASK mathematically .
22. State the bandwidth requirement of ASK system.
23. In BASK the information is transmitted via?
24. In a CW modulation system, the input signal ?
25. In a BASK system , the information is transmitted via ?
26. Express the BASK signal mathematica .
27. What does $\sqrt{2P_s}$ represent ?
28. The noise immunity of BASK system ?
29. What type of receiver is used for the BASK detection ?
30. What is the advantage of synchronous detection ?

31. What is the disadvantage of the BASK receiver ?
32. Explain the generation proven of ASK?
33. Differentiate ASK & PM?
34. Give the application of AM?
35. ASK is which type of modulation?
36. Compare ASK & FSK?
37. Define Nyquist rate?
38. What is meant by aliasing effect?
39. State Sampling theorem.
40. Give The Two Basic Operation Of Ask Transmitter?
41. Define Information Capacity?
42. What Is The Unit Of Information Capacity?
43. Why Digital Amplitude Modulation Is Commonly Called On –off Keying?
44. Why Digital Amplitude Modulation Is Called As Continuous Wave Modulation?
45. Define Bit Rate?
46. Define Phase Reversal Keying?
47. What Is The Need Of Maximum Distance Code?
48. What Is Quad Bits?
49. What is the difference between ASK and FSK?
50. What is meant by coherent ASK?

Real Time Applications:

- ASK is used in mobile applications
- In televisions
- Long distance communications
- TV broadcasting
- Digital audio in computers

FREQUENCY SHIFT KEYING: GENERATION AND DETECTION	EXPT. NO: 14
	DATE:

AIM:

Generate FSK modulated Signal and demodulate it by designing and implementing the corresponding Demodulator. Plot the corresponding waveforms from practical observations.

EQUIPMENT REQUIRED:

FSK modulation and demodulation kit

CRO-20/25MHz

BNC probes

Patch cards.

THEORY:

In FSK systems two sinusoidal carrier waves of same amplitude AC but different frequencies f_{c1} and f_{c2} are used to represent binary symbols 1 and 0 respectively. I.e.,
 $S(t) = A_c \cos(2\pi f_{c1} t)$ symbol 1 = $A_c \cos(2\pi f_{c2} t)$ symbol 2
The FSK is essentially a superposition of two ASK waveforms one with frequency f_{c1} and the other with f_{c2} . Hence the PSD of FSK is the sums of two ASK spectrums at frequencies f_{c1} and f_{c2} . The bandwidths of FSK are higher than that of PSK and ASK. The application of FSK signals is in low-speed digital data transmission.

Generation of FSK:

The FSK signal can be generated by applying the incoming binary data to a frequency modulator and to other input a sinusoidal carrier wave of amplitude AC and frequency f_c is applied. As the binary data changes from one level to another (but non zero being pear) the output changes its frequencies in the corresponding manner.

Detection of FSK:

FSK can be demodulated using synchronous or coherent detector. This type of detection or digital communication reception is also known as correlation reception. The coherent detection requires phase and time synchronization.

BLOCK DIAGRAM:

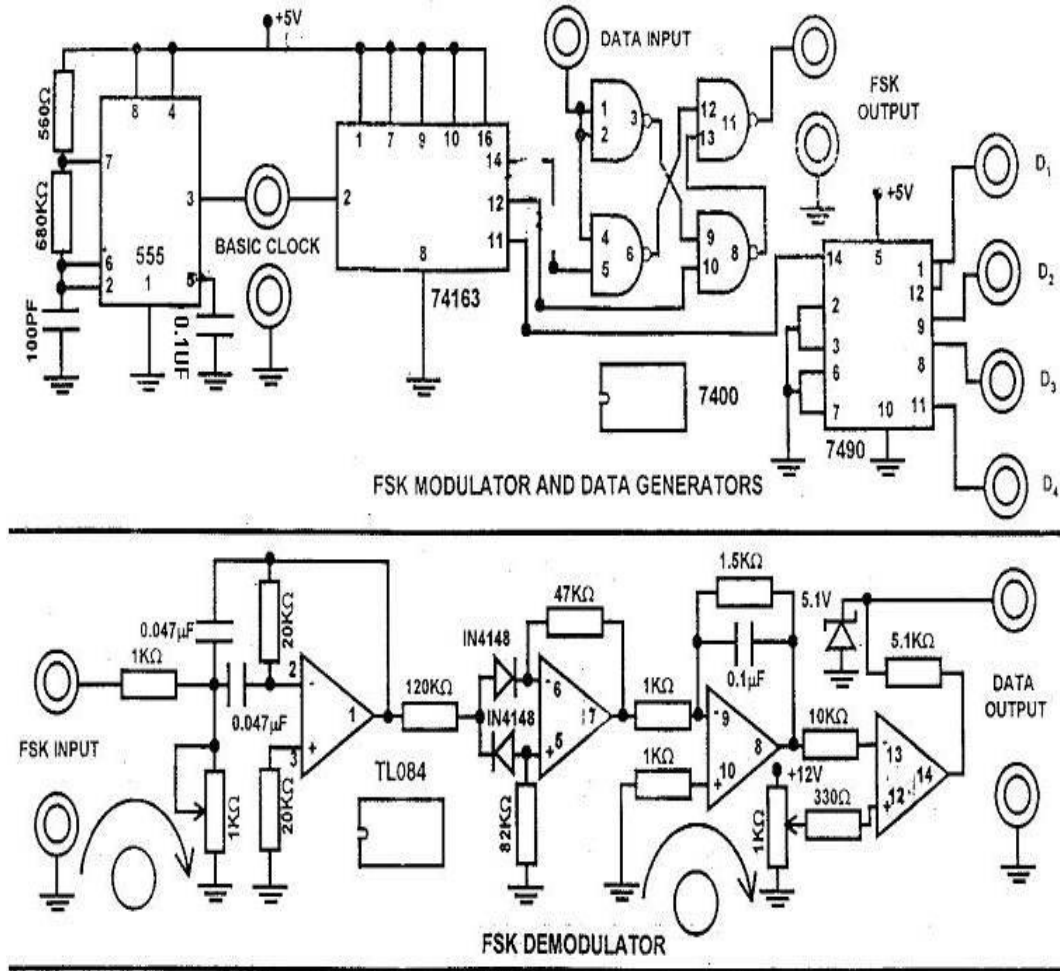

PROCEDURE:

1. Switch 'ON' the power to the Trainer.
2. Observe the clock frequency on the oscilloscope.
3. Apply the clock to the decade counter (7490). And vary the data outputs and draw the data outs.
4. Select one data output of the decade counter to the data input point of the FSK modulator and observe the same signal one channel of a dual trace oscilloscope.
5. Observe the output of the FSK modulator on the second channel of the CRO.

MODEL GRAPHS:

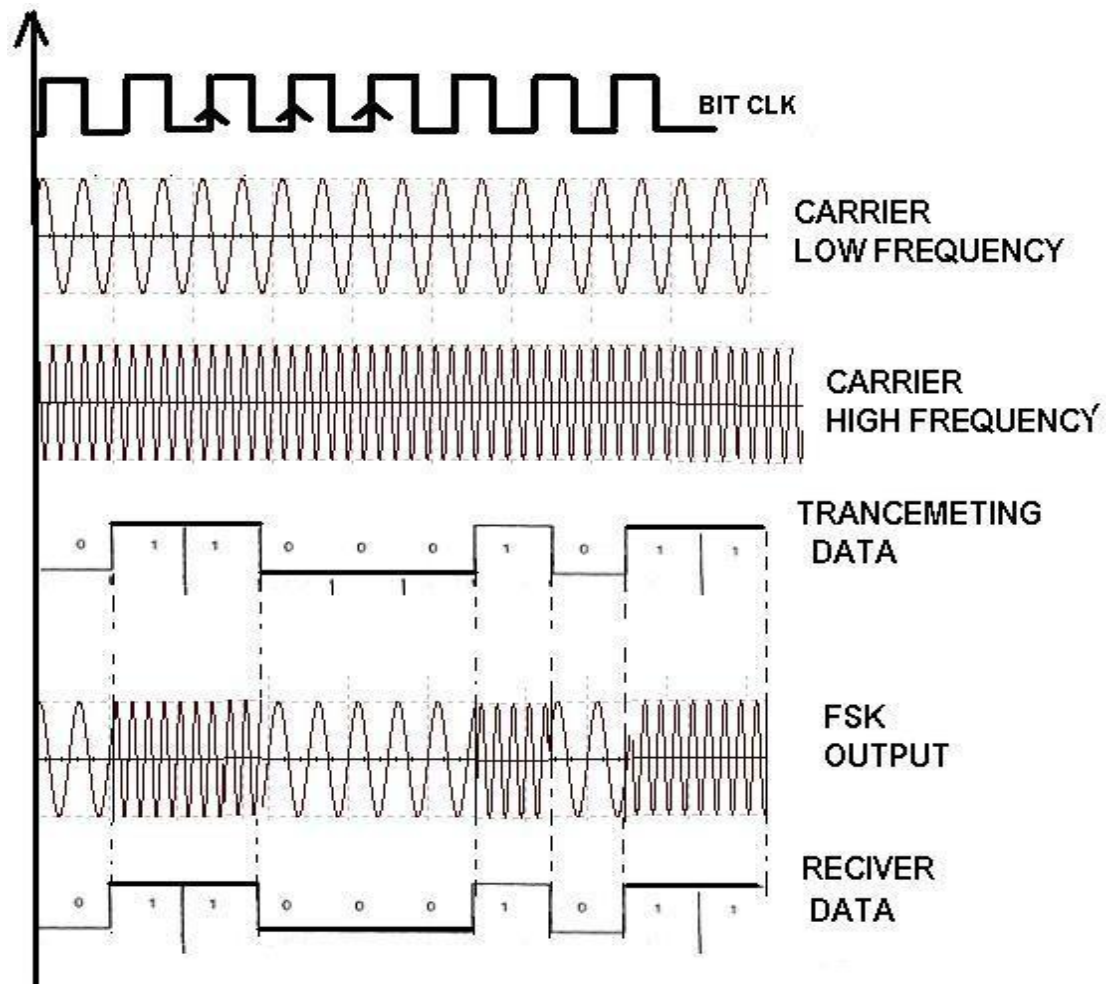

RESULT: -Hence generated frequency modulated and demodulated signals

VIVA QUESTIONS:

1. Define Binary FSK signal?
2. What is meant by carrier swing?
3. What is bandwidth of FSK signal?
4. Draw the Spectrum of FSK signal.
5. What are the digital modulation techniques?
6. Define Frequency deviation of FSK signal?
7. What are the advantages of this FSK signal?
8. Compare BFSK and BPSK?

9. Give the differences between FSK & FM?
10. Define Baseband transmission.
11. Define Pass band digital transmission.
12. What are the requirements of Digital Modulation Techniques?
13. What are the advantages of Digital Modulation Techniques?
14. What are the drawbacks of Digital Modulation Techniques?
15. Draw the waveforms for FSK signal for bipolar NRZ data.
16. Compare BFSK and ASK?
17. Why we use two carriers in FSK transmission and reception.
18. Define coherent detection.
19. Define non-coherent detection.
20. Compare all the digital modulation techniques?
21. What is the probability of error of FSK signal?
22. What is meant by frequency synthesizer?
23. Applications of frequency synthesizer.
24. What is meant by PLL?
25. Applications of PLL.
26. Define BER rate?
27. Write the expression for FSK signal for binary '1'?
28. Write the expression for FSK signal for binary '0'?
29. What is the major advantage of coherent FSK over coherent PSK?
30. Compare BFSK and QPSK?
31. Draw the block diagram of FSK signal detection using coherent detection.
32. Draw the block diagram of FSK signal detection using non-coherent detection.
33. Draw the block diagram of FSK signal detection using PLL.
34. Write the expression for bit error rate for coherent binary FSK.
35. What is correlator?
36. Compare ASK, PSK and FSK based on their power?
37. Compare ASK, PSK and FSK based on their SNR?
38. Compare ASK, PSK and FSK based on their probability of error?
39. Define modulation rate.
40. What BER rate of FSK signal.

41. Define coherent detection.
42. Define non-coherent detection.
43. Compare all the digital modulation techniques?
44. What is the probability of error of FSK signal?
45. What is the major advantage of coherent FSK over coherent ASK?
46. What are the three broad types of synchronization?
47. What is carrier synchronization?
48. Compare ASK, PSK and FSK based on their bandwidth?
49. Draw the time domain waveforms of FSK signal.
50. What is expression for FSK signal?

Real Time Applications:

- Amateur radio
- Caller ID
- Emergency broadcasting
- Finance business
- General purpose PLL applications

Bluetooth or BLE(Bluetooth Low Energy) which normally used everywhere like in mobile phone, wireless speakers, Laptops, etc uses **GFSK(Gaussian Frequency Shift Keying)** modulation technique for data transmission. Difference between GFSK and FSK is nothing but GFSK has an additional Gaussian Filter to reduce the side band power.

AIM:

To generate practically Binary PSK modulated Signal and demodulate it by designing and implementing the corresponding Demodulator. Plot the corresponding waveforms from practical observations.

EQUIPMENT REQUIRED:

- PSK Modulations and Demodulation Trainer kit
- CRO
- BNC probes
- Patch cards

THEORY:

Phase shift keying or discrete phase modulation is another technique available for communicating digital information over band pass channels. The PSK is a form of angle modulated, constant amplitude digital modulation. In binary phase shift keying two output phases are possible for a single carrier frequency as the input digital signal changes state, the phase of the output carrier shifts between 180° out of phase. In binary phase shift keying modulation the balanced modulator acts as a phase reversing switch. Depending on the logic condition of the digital input, the carrier is transferred to the output either in phase or 180° with reference carrier oscillators. and for proper operation the digital input voltages must be greater than the peak carrier voltage as it has to control ON-OFF of diodes. The coherent detection also called synchronous detection is used for binary phase shift keying detection. It is more complicated than envelope detector, and results in a lower probability of error for a given S/N input. Synchronous detection requires a carrier recovery circuit to generate local carrier component exactly synchronized to the transmitted carrier.

MODEL GRAPHS:

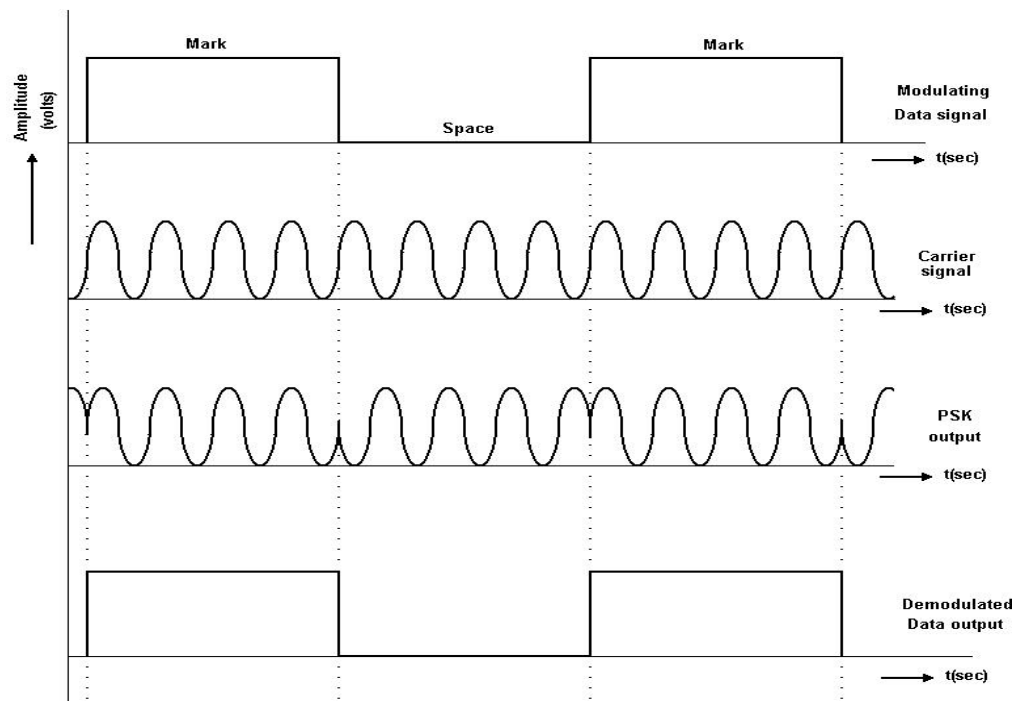

PROCEDURE: -

1. Switch ON the experimental board.
2. Apply the carrier signal to the input of the modulator.
3. Apply the modulating data signal to the modulator input and observe this signal on one channel 1 of the CRO.
4. Observe the output of the PSK modulator on the channel 2 of the CRO.
5. Apply this PSK output to the demodulator input and also apply the carrier input.
6. Observe the demodulator output and compare it with the modulating data signal applied to the modulator input.

RESULTS: - Hence generated Phase modulated and demodulated signals

VIVA QUESTIONS:

1. Define PSK?
2. Explain the generation proven of PSK?
3. Differentiate PSK & PM?
4. Give the application of PSK?
5. PSK is which type of modulation?
6. Compare PSK & FSK?
7. Give the advantages PSK?
8. Define Nyquist rate?
9. What is meant by aliasing effect?
10. State Sampling theorem.
11. Explain How Qpsk Differs From Psk In Term Of Transmission Bandwidth And Bit Information It Carries?
12. Give The Equation For Average Probability Of Symbol Error For Coherent Binary Psk?
13. Define Qpsk?
14. Give The Two Basic Operation Of Dpsk Transmitter?
15. Define Information Capacity?
16. What Is The Unit Of Information Capacity?
17. Why Digital Amplitude Modulation Is Commonly Called On –off Keying?
18. Why Digital Amplitude Modulation Is Called As Continuous Wave Modulation?
19. Define Bit Rate?
20. Define Baud?
21. Define Phase Reversal Keying?
22. What Is Offset Qpsk?
23. What Is Eight Phase Psk?
24. What Is The Need Of Maximum Distance Code?
25. What Is Quad Bits?
26. Define Dpsk?
27. What Is The Need For Ber?
28. Define ASK?

29. What is meant by DPSK?
30. Explain coherent detection?
31. What is the difference between PSK and FSK?
32. What is meant by coherent ASK?
33. What is the major advantage of coherent PSK over coherent ASK?
34. Explain the model of bandpass digital data transmission system?
35. What is baseband signal receiver?
36. What is matched filter?
37. What is the value of maximum signal to noise ratio of the matched filter? When it becomes maximum?
38. What is correlator ?
39. On what factor, the error probability of matched filter depends.
40. Bring out the difference between coherent & non coherent binary modulation scheme.
41. Write the expression for bit error rate for coherent binary FSK.
42. Highlight the major difference between a QPSK & MSK signal.
43. What is the error probability of MSK & DPSK?
44. Compare Ask with psk signal?
45. What is the error probability of MSK?
46. Compare psk with fsk signal?
47. What are the disadvantages of psk?
48. What are the advantages of qpsk over psk?
49. What is the error probability of PSK?
50. Compare PSK QPSK DPSK?

Real Time Applications:

- Wireless LANs.
- RFIDs.
- Bluetooth Communication.
- Radio Communications.